

| INSTALLATION & OPERATION MANUAL

MBF 700 Inline Turbine Flow Meter



MIAL[®]
INSTRUMENTS PVT.LTD.
Measuring & Beyond

www.mialinstruments.com

MBF 700

Inline Turbine Flow Meter

Preface

- Thank you for purchasing our product.
- This manual is about the various functions of the product, wiring methods, setting methods, operating methods, troubleshooting methods, etc.
- Please read this manual carefully before operation, use this product correctly to avoid unnecessary losses due to incorrect operation.
- After you finish reading, please keep it in a place where it can be easily accessed at any time for reference during operation.



NOTE!

Modification of this manual's contents will not be notified as a result of some factors, such as function upgrading. We try our best to guarantee that the manual content is accurate, if you find something wrong or incorrect, please contact us. The content of this manual is strictly prohibited from reprinting or copying.

About this manual

- Please submit this manual to the operator for reading.
- Please read the operation manual carefully before applying the instrument. On the precondition of full understanding.
- This manual only describes the functions of the product. The MIAL Instruments pvt.ltd. Does not guarantee that the product will be suitable for a particular use by the user.

Warnings and symbols used



HAZARD!

If not taken with appropriate precautions, will result in serious personal injury, product damage or major property damage.



WARNING!

Pay special attention to the important information linked to product or particular part in the operation Manual



CAUTION!

Disregarding these instructions can result in damage to the device or to parts of the operator's plant.



INFORMATION!

These instructions contain important information for the handling of the device.



Table of Contents

PREFACE	1
ABOUT THIS MANUAL	1
1. INTRODUCTION	3
1.1 PURPOSE OF THE MANUAL.....	3
1.2 OPERATING PRINCIPLE	4
1.3 TECHNICAL SPECIFICATIONS.....	5
2. DEVICE DESCRIPTION	6
2.1 SCOPE OF DELIVERY	6
2.2 NAMEPLATES.....	6
2.3 OVERALL DIMENSION.....	7
3. INSTALLATION	9
3.1 SITE SELECTION.....	9
3.1.1 BASIC RECOMMENDATIONS	9
3.1.2 STRAIGHT LENGTH REQUIREMENT	9
4 ELECTRICAL CONNECTIONS	12
4.1 SAFETY INSTRUCTION.....	12
4.2 TB3WE THREE-WIRE SYSTEM ELECTRIC WIRING	12
4.3 TB2WE THREE-WIRE SYSTEM ELECTRIC WIRING.....	13
5 OPERATION	15
5.1 WORKING MENU	15
5.2 USER'S DATA SETTING	16
5.3 USER PARAMETER SETTING MENU	17
APPENDIX -1	18



1. INTRODUCTION

1.1 PURPOSE OF THE MANUAL

Overview:

Welcome to the user manual for the Mial MBF 700 – Inline Turbine Flowmeter. This comprehensive guide is designed to assist operators, maintenance personnel, and system integrators in understanding, installing, operating, and maintaining the Mial MBF 700 – Inline Turbine Flowmeter effectively.

Objectives:

Clarification of Functionality: This manual aims to provide a clear understanding of the principles and functionality of the Mial MBF 700 – Inline Turbine Flowmeter. Users will gain insights into its design, components, and how it precisely measures fluid flow.

Guidance for Installation:

Step-by-step instructions and considerations for proper installation are provided to ensure optimal performance. Safety precautions are emphasized to create a secure working environment.

Training and Familiarization:

Users will be guided through the features, controls, and indicators of the flow meter, facilitating efficient operation. This section aims to serve as a valuable training resource for users at various experience levels.

Maintenance and Troubleshooting Assistance:

Learn about routine maintenance procedures and effective troubleshooting techniques. This manual empowers users to address common issues and perform regular maintenance to enhance the longevity of the Mial MBF 700 – Inline Turbine Flowmeter

Intended Audience:

This manual is intended for operators, maintenance personnel, and system integrators involved in the installation, operation, and maintenance of the Mial MBF 700 – Inline Turbine Flowmeter. It is suitable for both novice users seeking basic guidance and experienced professionals looking for specific details.

Important Notes:

Please read through the manual carefully, adhering to safety guidelines and following instructions precisely. If any uncertainties arise during the installation, operation, or maintenance processes, seek assistance from qualified personnel or our customer service / support team.

Reference to Other Documentation:

Refer to the accompanying technical specifications document for in-depth details about the Mial MBF 700 – Inline Turbine Flowmeter. Additional resources can be found on our website.

Intended use



CAUTION!

Responsibility for the use of the measuring devices with regard to suitability, intended use and corrosion resistance of the used materials against the measured fluid lies solely with the



operator.



INFORMATION!

The manufacturer is not liable for any damage resulting from improper use or use for other than the intended purpose

Certification



The manufacturer certifies successful testing of the product by applying the ISO marking

1.2 OPERATING PRINCIPLE

When liquid flows through the casing of sensor, the impulse of fluid will provide the blade with a rotation moment as there is an angle between the blade of impeller and the flow direction. The blade will rotate as the friction moment and the fluid resistance are overcome and it will reach a stable speed when the moments are at balance. Under certain conditions, the rotation speed of blade will be in direct proportion to the flow velocity. Due to the magnetic conductivity of blade, when located in the magnetic field generated by signal detector (made of permanent magnet steel and coils), the rotating blade will cut the magnetic lines and periodically change the flux through the coil, thereby inducing electrical impulse signals at both ends of the coil. The induced signals, after amplified and rectified by amplifier, will form a continuous rectangular impulse wave with certain amplitude which may be remotely transmitted to display instrument indicating the instant flow and the cumulative flow of fluid. Within a certain range of flow, the impulse frequency f is in direct proportion to the instant flow of fluid flowing through the sensor, which is shown in the equation below:

$$Q = 3600 \times f / k$$

Wherein:

f - Impulse frequency [Hz];

k - Instrument factor of sensor [1/m³], which is given by checklist. If [1/L] is used as

$$Q = 3.6 \times f / k$$

the unit, the equation will be:

Q - Instant flow of liquid (in operation) [m³/h];

3600- Conversion factor.

Instrument factor of each sensor will be filled out in verification certificate by the manufacturer. The instant flow and cumulative flow will be displayed when the value of k is loaded into associated display instrument.



1.3 TECHNICAL SPECIFICATIONS*

Operation and performance

Flow measurement

Turbine rotation technology

Fluid types

Most Clean Liquids

Fluid properties

Fluid with viscosity: 20 CST

Nominal drift diameter

DN 15 MM – DN 200 MM

Flow accuracy

±0.5%;

Measurement parameters

Standard: Total Flow, Instantaneous Flow,

Optional: Medium Pressure, Medium Temperature

Certification

Factory wet Calibration certificate & Test Report

Nominal Pressure

DN 15 –DN 50: 4Mpa

DN 65 –DN 200: 1.6Mpa

Process connections

ANSI 150 Flanges

Sensor Materials

Standard: Stainless Steel 304

Optional: Stainless Steel 316

Electronics

Transmitter Type

Integral

Enclosure IP rating

IP65

Power supply

24 VDC/2A

Use SMPS when employing AC power

Ambient temperature

32°F to 140°F (0°C to 60°C)

Standard output

Analog output: 4-20mA

Pulse output

Network Connection

Modbus RTU RS 485

Operating Temperature range

-4°F to 176°F (-20°C to 80°C)



2. DEVICE DESCRIPTION

2.1 SCOPE OF DELIVERY



INFORMATION!

Do a check of the packing list to make sure that you have all the elements given in the order



INFORMATION!

Inspect the packaging carefully for damages or signs of rough handling. Report damage to the carrier and to the local office of the manufacturer.

2.2 NAME PLATES



INFORMATION!

Look at the device nameplate to ensure that the device is delivered according to your order. Check for the correct supply voltage printed on the nameplate

EXAMPLE OF NAMEPLATE FOR THE TRANSMITTER

Turbine Flow Meter	
Model: _____	Measuring Range: _____
Factor: _____	Nominal Diameter: _____
Accuracy : _____	Nominal Pressure : _____
Date : _____	Serial Number : _____

2.3 OVERALL DIMENSION

The installation types of sensors vary according to specifications, which may be connected either by thread or flange. The installation types are shown in Fig. 1, Fig. 2, Fig.3, Fig. 4 and Fig. 5. The installation dimensions are shown in Table 2.

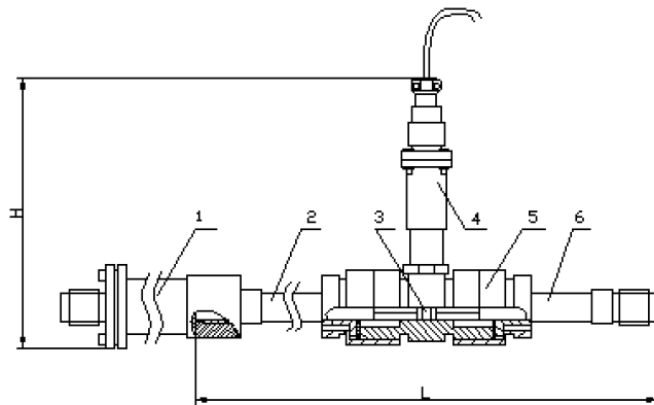

- 1. Filter
- 2. Front straight pipe section
- 3. Impeller
- 4. Preamplifier
- 5. Casing
- 6. Rear straight pipe section

Fig. 1 Structure of DN4~DN10 sensor and installation dimension diagram

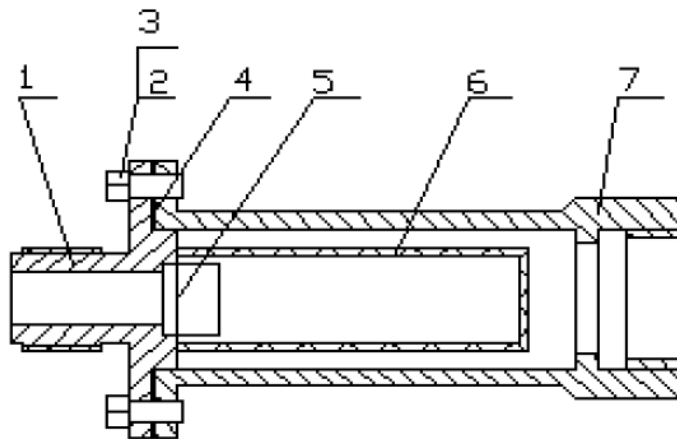

Fig. 2 Filter structure diagram

- 1. Clamp ring
- 2. Bolts 4x14
- 3. Washer
- 4. Sealing washer
- 5. Steel wire 1Cr18Ni9Ti-0.8x2.5
- 6. Filter screen
- 7. Base

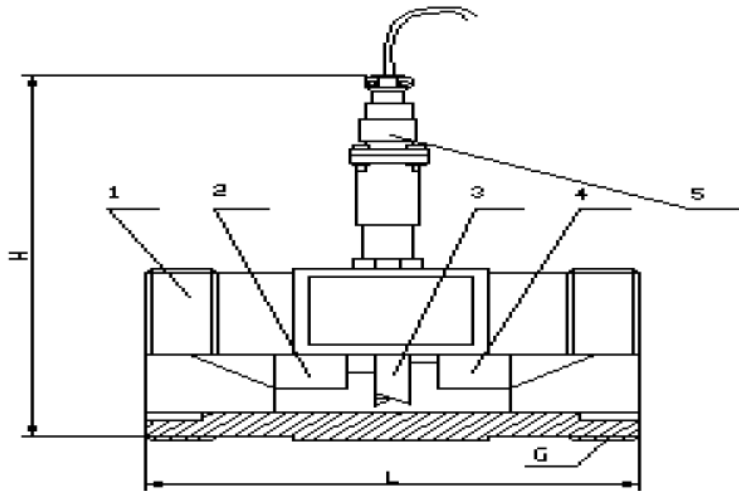

Fig. 3 Structure of DN15~DN40 sensor and installation dimension diagram

- | | |
|---------------------|--------------------|
| 1. Casing | 4. Rear guide part |
| 2. Front guide part | 5. Preamplifier |
| 3. Impeller | |

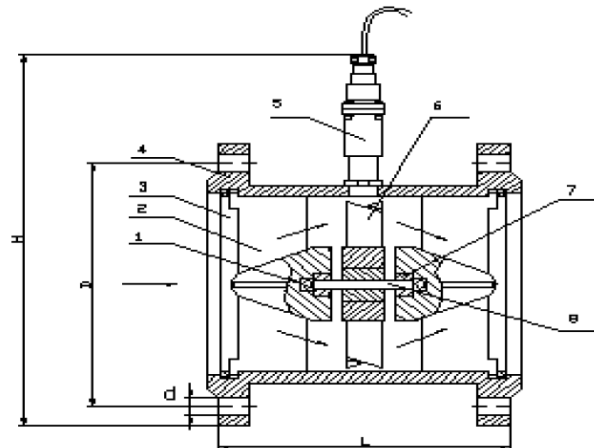

Fig. 4 Structure of MBF700—50~200 sensor and installation dimension

- | | |
|---------------------|-----------------|
| 1. Ball bearing | 5. Preamplifier |
| 2. Front guide part | 6. Impeller |
| 3. Expansion ring | 7. Bearing |
| 4. Casing | 8. Shaft |



3. INSTALLATION

3.1 SITE SELECTION

When selecting a site for a flow meter, prioritize accessibility for installation and maintenance. Consider environmental factors like temperature and humidity as per guidelines. Ensure the flow profile is stable and the pipe is in good condition. Safety and ease of access for personnel should also be taken into account to optimize meter performance and longevity.

3.1.1 BASIC RECOMMENDATIONS

In general guidelines, it's recommended to find a location where the pipe has the longest straight segment with a clear run. This ensures smooth and consistent flow of the fluid through the meter, which is crucial for accurate measurement. A longer clear run of pipe minimizes disturbances and turbulence that could affect the meter's performance. This approach helps optimize the meter's accuracy and reliability by providing a stable flow profile for measurement. When sensor is used, the liquid to be measured shall be clean and free of impurities such as fiber and granules. When sensor is used, it shall be at first slowly filled with liquid, then open the outlet valve (which should be installed behind the flow meter). It is prohibited to render the sensor under impact of high-velocity fluid when it is not filled with liquid. The maintenance interval for sensor is in general half a year. In case of maintenance and cleaning, attention shall be paid not to damage the parts in the measuring cavity, particularly the impeller. During assembly, watch carefully the positional relation between guide part and impeller. When the sensor will be out of service for a long time, the internal liquid shall be cleaned. After dried, the sensor shall be provided with protection sleeves at both ends to protect against dust and it shall be placed in dry conditions for storage. The associated filter shall be cleaned on regular basis and the internal liquid shall be cleaned when it is out of service for a long time. Similar to sensor, the filter shall also be provided with dust protection and stored in dry conditions. The transmission wire of sensor may be overhead or buried (iron bushing shall be provided in the latter case). Prior to installation of sensor, the connection thereof with display instrument or oscilloscope shall be finished. Then switch on the power, blow the impeller with mouth or move the impeller with hand to make it rotate quickly, see if there is any reading. Install the sensor if there is reading. In case of no reading, the related sections shall be inspected to eliminate any fault.

3.1.2 STRAIGHT LENGTH REQUIREMENT

Flow meter may be installed horizontally or vertically. In the latter case the fluid shall be flowing from downward and fulfill the pipe to avoid bubbles; the flowing direction of liquid shall be consistent with the direction indicated by the arrow on casing of the sensor; as far as front and rear straight pipe sections are concerned, at upstream there shall be front straight pipe section at least 10 times of nominal drift diameter in length and at downstream no less than 5 times of nominal drift diameter in length. The internal wall of pipe sections shall be smooth and clean, free of defects such as indent, fouling and peeling. The pipe axis of the sensor shall be aligned with that of the neighboring pipe and the washers used for connection and sealing may not be embedded into depth of the pipe cavity; the sensors shall be kept away from foreign electric field and magnetic field, effective shielding measures shall be taken in case of necessity to avoid external interference. In order that the normal transfer of liquid will not be affected by maintenance, it is recommended that bypass pipes be installed at position of sensor. In case of open air installation, water proof measures shall be taken for purpose of amplifier and plug of the sensor. The wiring between sensor and display instrument is shown in Fig. When fluid contains impurities, filter shall be additionally installed. The number of filter screen meshes is determined in accordance with the flow and impurity, normally 20 to 60 meshes. When fluid is mixed with free gases, gas eliminator shall be additionally installed. The complete pipe system shall be well



sealed. The user shall fully understand the erosion nature of the measured medium to protect the sensor from being eroded.

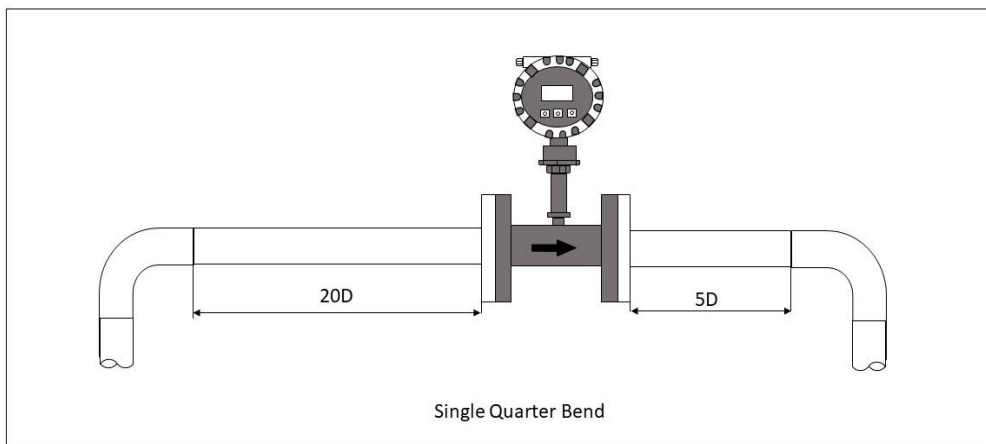
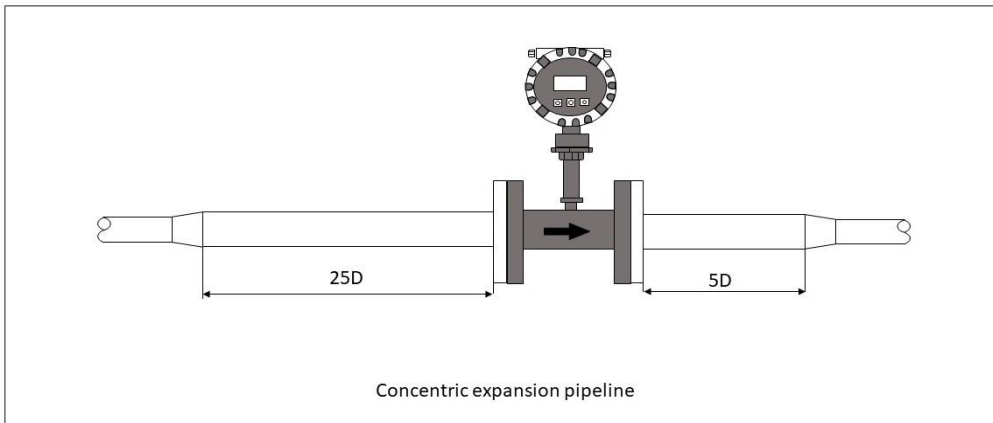
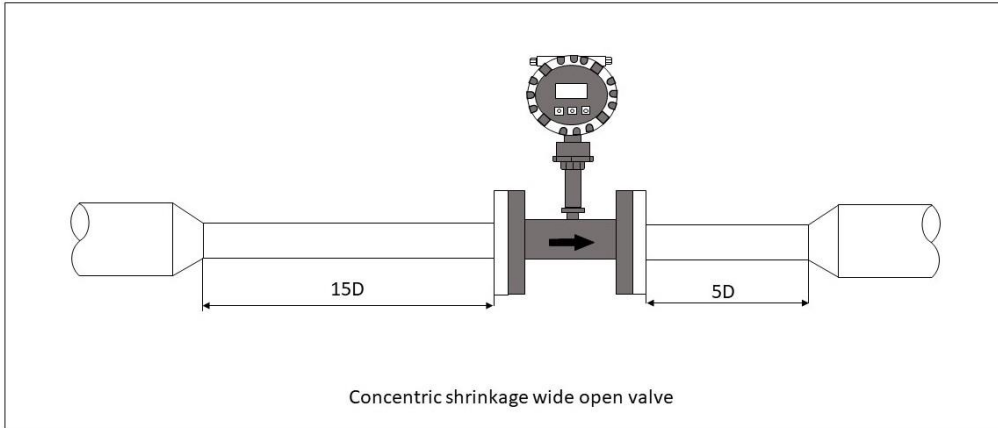

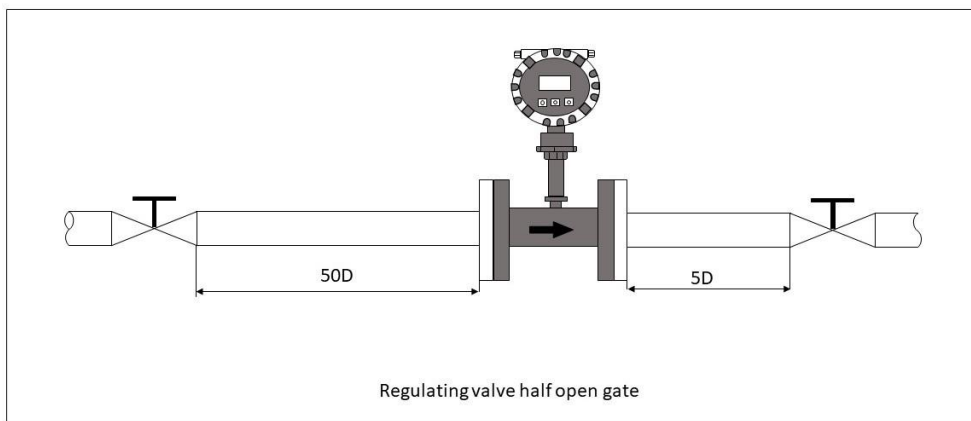
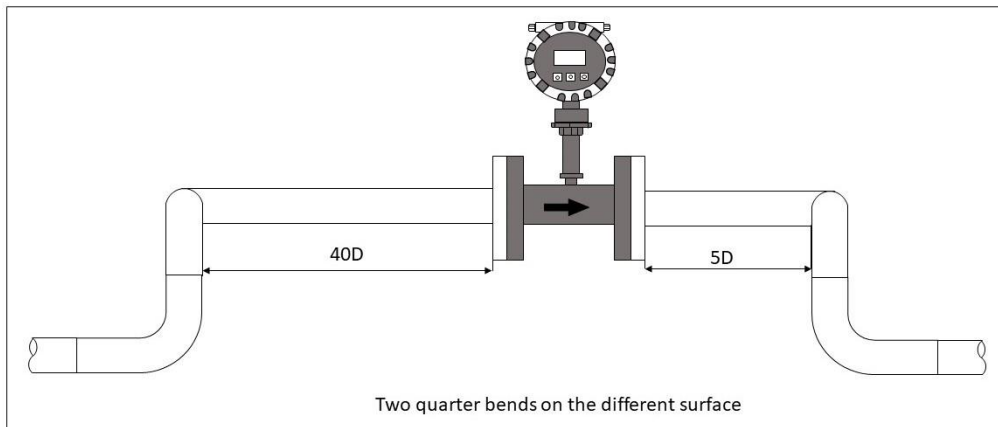
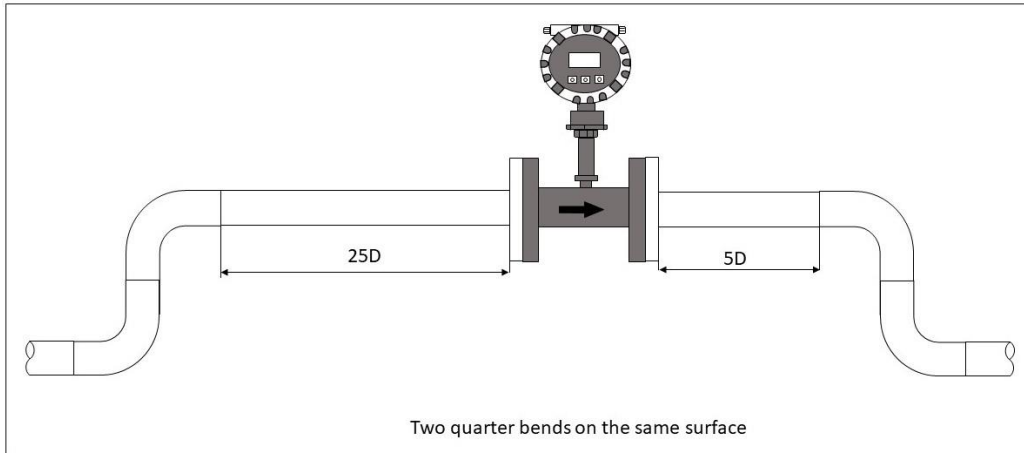



4 ELECTRICAL CONNECTIONS

4.1 SAFETY INSTRUCTIONS



DANGER!

Only when power is switched off, can we do all the work about electrical connections. Please pay all attention to the power supply on the name plate!



DANGER!

Observe the national regulations for electrical installations!



DANGER!

For devices used in hazardous areas, additional safety notes apply; please refer to the Ex documentation.



WARNING!

Observe without fail the local occupational health and safety regulations. Any work done on the electrical components of the measuring device may only be carried out by properly trained specialists.



INFORMATION!

Look at the device nameplate to ensure that the device is delivered according to your order. Check for the correct supply voltage printed on the nameplate.



INFORMATION!

Connect the cable on connector with similar numeral marking

4.2 TB3WE THREE-WIRE SYSTEM ELECTRIC WIRING

1. MAIN POWER SUPPLY AND OUTPUT SIGNAL TERMINALS

(3-digit under-hang spinning terminals in the left).

Fout	-	+
------	---	---

Fout: Pulse Signal Output Terminal

“-”is the power supply “-” or current flow terminal

“+”is external 24VDC power “+”



When “+” “-” connect (or battery type power on), pulse output from “Fout”.

2. AUXILIARY WIRE (SMALL TERMINAL)

The three-wire between main terminal and auxiliary terminal are pulse output switch. If insert into the outside F0, there will be pulse output. If insert into the inside NC, then no pulse output. For two wire current type, only insert outside F0 while testing. If use current, must insert inside NC to disconnect pulse output. Or else, the current will not be accuracy.

3. BATTERY POWERED TYPE

+3V6	3V6-	B-	A+
------	------	----	----

Battery Wiring (the right side 1 and 2 in small terminal)

+3V6: Connect 3.6V battery “+”

3V6-: Connect 3.6V battery “-”

Communication Wiring

(the left side 3 and 4 in small terminal, if without RS485, no terminal here)

B-: Connect RS485 “B-”

A+: Connect RS485 “A+”

4.3 TB2WE THREE-WIRE SYSTEM ELECTRIC WIRING

1. MAIN POWER SUPPLY AND OUTPUT SIGNAL TERMINALS

Fout	-	+
------	---	---

“-”:4-20mA output terminal

“+”: 24V power “+” terminal

“+” Connect with +24V external power, current output from “-” to computer/sample resistance of the display. After flow through some load resistance like sample resistance, then back to power “-”.

2. AUXILIARY WIRE (3-DIGIT SMALL TERMINAL)

4-20mA current output type with no auxiliary small terminals.

Fout: Pulse output terminal

When “+” “-” connect with external power then work, pulse output from “Fout”.

The three-wire near main terminal are pulse output switch.

If connect to the outside F0,there will be pulse output.

If connect to the inside, then no pulse output.

For two wire current type, only insert outside while testing.



If use current, must insert inside NC to disconnect pulse output. Or else, the current will not be accuracy.

This pulse is origin pulse without any modify, usually use while doing calibration; Output signal is the open-collector output include 2K7 pull-up resistor.

System wiring please refer to the appendix "TB3WE three wire" and "TB2WE Two Wire".



5 OPERATION

5.1 WORKING MENU

After power-on, meter will be self-checking first, after then it will enter into LCD (figure 1) working display status.

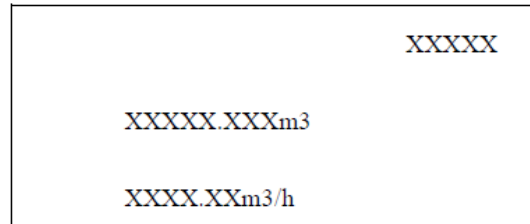

Chart 1 TB2/3WE working screen (Figure One)

The first line: High level of Accumulative flow; 5 fixed integer part number. If no, it'll display as "0".
 The second line: Low level of Accumulative flow; 3 decimals part number after the 5 fixed integer number. The unit is the same with instant flow non-time part.
 The third line: Instantaneous Flow; 5 or 6 integers and automatic keep 2 or 1 decimals. The unit can be set.

Press "<" or "+" to change the screen from Working Screen 1 and 2

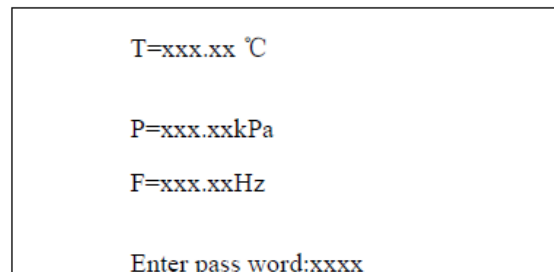

Chart 2 TB3WE Three-wire System working screen (Figure Two, Sub Screen)

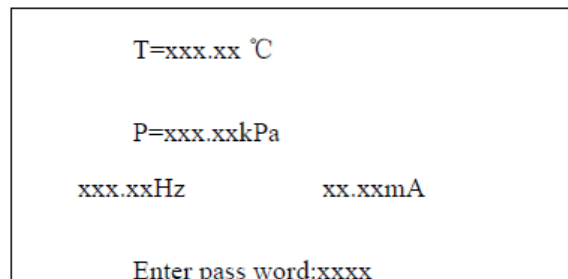

Chart 3 TB2WE Three-wire System working screen (Figure Two, Sub Screen)

From Up to Down:

The first line: Temperature value setting for temperature compensation calculation, shows "T=999.9°C", reserving 1 decimal.

The second line: Pressure value setting for pressure compensation Calculation, shows "



P=99999.99kPa", reserving 2 decimals.

The third line: For TB3WE is frequency value. For TB2WE is frequency value (left side) and current output (right side)

The four line: password entering set state. Press the enter key of "<" (about 1.2seconds) to enter password initial input state.

Press the key of "+" (about 1.2seconds) to cancel entering state and return to figure two Subsidiary LCD.

Press "+"key in the input state to change the value of cursor circularly.

Press the shift key "<" to change the position of input cursor.

Press "<"key (about 1.2seconds) at the input state to submit the password. If right, enter to menu. if incorrect, return to initial input state.

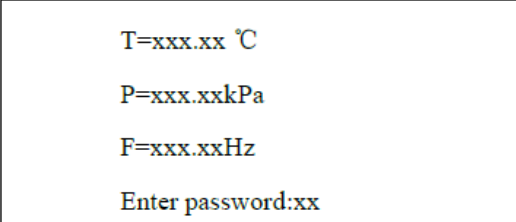

```
T=xxx.xx °C
P=xxx.xxkPa
F=xxx.xxHz
Enter password:xx
```

Chart 4 Password Initial Input State

Password: User menu password 2010

5.2 USER'S DATA SETTING

1.Input operation In the input state:

Pre "++"key in a long time to exit the input state.

Pre "<"key to confirm and save the input.

Press "+"key in the input state to change the value or symbol of cursor circularly.

Press "<"key to move the current cursor one position towards the right.

Max.8 digits inputting is allowed. (including the symbol, decimal).

2.Menu Operation In the menu browse:

Press "+" key for page down;

Press "<"key for page up;

Long Press "<"key for entering into the sub-menu;

Long press "+" key for returning to the working screen figure 2;

In the sub-menu, long press "+" key to quit out; long press "<"key to enter into modified state; In the modified state, press "+" key for downward selecting; press "<"for upward selecting; long press "<"key for confirmation and saving.

Attention: When the parameter setting, it should long press "<"key for saving the displaying. Otherwise, the setting is invalid.



5.3 USER PARAMETER SETTING MENU

Sub-menu Series#	Display of menu	Definition	Alternative options or range of value
1	Flow Unit select	Flow Unit select (default 0)	0: m ³ /h 1: m ³ /m 2: l/h 3: l/m 4: t/h 5: t/m 6: kg/h 7: kg/m
2	Algorithm Selection	Algorithm Selection (default 0)	00:Conventional Volume flow 01:Conventional mass flow 02:Volume flow of conventional gases 03:Mass flow of conventional gases
3	Flow Coefficient	Flow Coefficient (default 3600)	Set the meter coefficient with the unit of P/m ³
4	Maximum Output Flow	Max. Flow (default 1000)	When the meter outputs 4~20mA analog signal, must set the value and the value cannot be zero,the unit should be accordance with the flow unit.
5	Density setting	Density setting (default 1.0)	When Algorithm Selection is setting to mass flow(01,03),it must set this item,the unit is kg/m ³
6	Temperature Setting	Temperature Setting (default 0.0)	Setting the temperature calculated value,when choose 02,03,04,06 algorithm,it must set this item,the unit is Celsius degree.
7	Absolute pressure setting	Gas Absolute pressure set (default 101.325)	Setting the absolute pressure of gas,when choose 02,03 algorithm,it must set this item,the unit is Kpa.(when vacuum is 0.0,it will cause the flow is 0)
8	Low flow cut off	Set percentage of resection pulse input (Default 1%)	The value is between 0~100
9	485 Address	Set RS485 communication No. (Default 1)	For three-wire system TB3WE only.The meter uses RS485 communication should set this item,and should not equal to other equipment in the same system,the range is 0~255.
10	Damping time	Set current output damping time (Default 4s)	Setting current and displaying damping time,it is for avoiding the current's fluctuation too big along with the flow rate.The range is 2~32.
11	Reset Cumulant	Reset cumulant	If need to Reset cumulant,choose YES and press "E" key.



Appendix - I

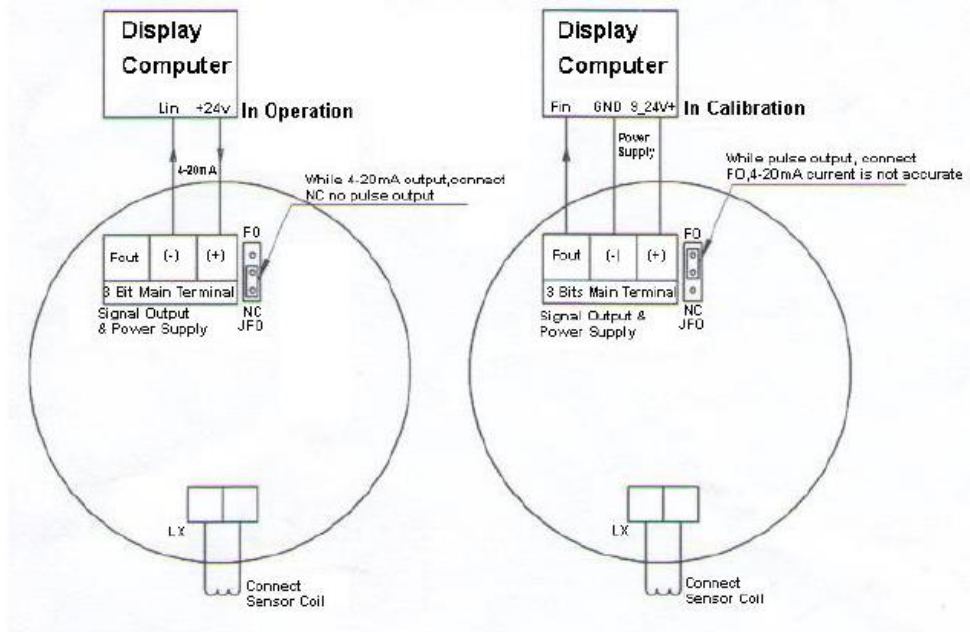

Appendix 3: TB3WE Three-wire System Turbine Flow Meter Wiring Scheme

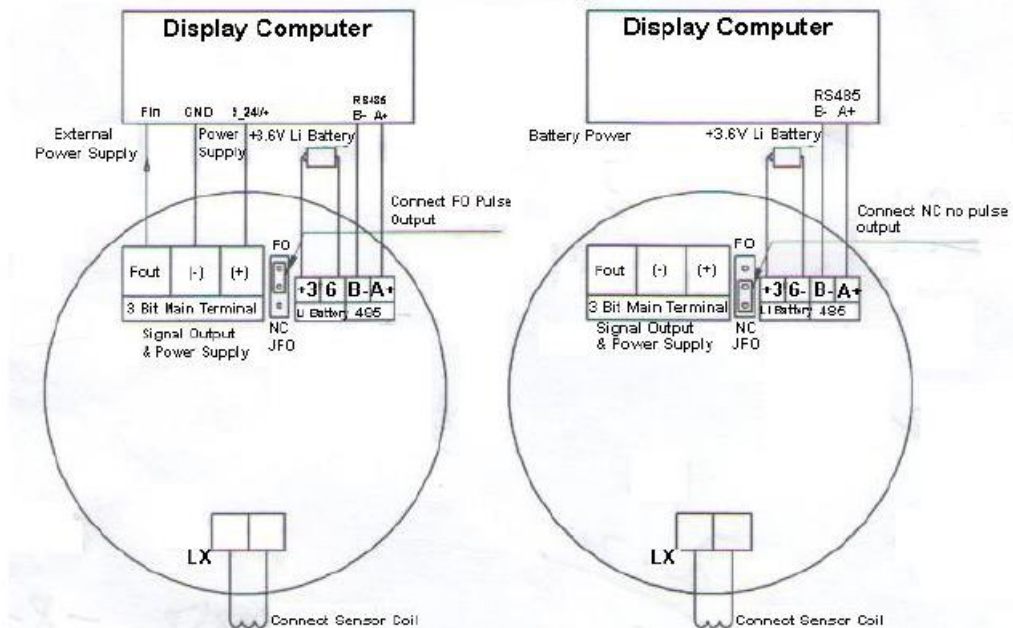



MIAL[®]
INSTRUMENTS PVT.LTD.
Measuring & Beyond

USA OFFICE ADDRESS

MIAL INSTRUMENTS PVT. LTD.
Downtown Republic Center
325 N. St.Paul Street, Suite 3100
Dallas 75201, Texas, USA

FACTORY ADDRESS

MIAL INSTRUMENTS PVT. LTD.
856/ 6 GIDC
Makarpura, Vadodara 390010, Gujarat, India
+91-9913449547/9913449548

Email : info@mialinstruments.com
www.mialinstruments.com



**MIAL
INSTRUMENTS**
Measuring & Beyond

856/6, GIDC MAKARPURA, VADODARA - 390010
Phone : +91-9913449547 / +91-9913449548
E-MAIL : info@mialinstruments.com
WWW : www.mialinstruments.com