

| INSTALLATION & OPERATION MANUAL

MEF(B)2100 Inline Electromagnetic BTU Meter



MIAL[®]
INSTRUMENTS PVT.LTD.
Measuring & Beyond

www.mialinstruments.com

MEF(B) 2100

Inline Electromagnetic BTU Meter

Preface

- Thank you for purchasing our product.
- This manual is about the various functions of the product, wiring methods, setting methods, operating methods, troubleshooting methods, etc.
- Please read this manual carefully before operation, use this product correctly to avoid unnecessary losses due to incorrect operation.
- After you finish reading, please keep it in a place where it can be easily accessed at any time for reference during operation.



NOTE!

Modification of this manual's contents will not be notified as a result of some factors, such as function upgrading. We try our best to guarantee that the manual content is accurate, if you find something wrong or incorrect, please contact us. The content of this manual is strictly prohibited from reprinting or copying.

About this manual

- Please submit this manual to the operator for reading.
- Please read the operation manual carefully before installing the instrument. On the precondition of full understanding.
- This manual only describes the functions of the product. The MIAL Instruments pvt.ltd. does not guarantee that the product will be suitable for a particular application.

Warnings and symbols used



HAZARD!

If not taken with appropriate precautions, will result in serious personal injury, product damage or major property damage.



WARNING!

Pay special attention to the important information linked to product or particular part in the operation Manual



CAUTION!

Disregarding these instructions can result in damage to the device or other ancillary products.



INFORMATION!

These instructions contain important information for the handling of the device.



Table of Contents

PREFACE	1
ABOUT THIS MANUAL	1
1. INTRODUCTION	4
1.1 PURPOSE OF THE MANUAL	4
1.2 OPERATING PRINCIPLE.....	5
1.3 TECHNICAL SPECIFICATIONS	6
1.4 SUPPLEMENTARY ACCESSORIES THAT COULD BE NEEDED.....	8
1.4.1 GROUNDING RINGS.....	8
2. DEVICE DESCRIPTION	9
2.1 SCOPE OF DELIVERY.....	9
2.2 NAMEPLATES	9
3. INSTALLATION	11
3.1 SITE SELECTION	11
3.1.1 BASIC RECOMMENDATIONS.....	11
3.1.2 FLOW DIRECTION.....	11
3.1.3 INSTALLATION OF REMOTE MOUNT TRANSMITTER.....	11
3.1.4 STRAIGHT LENGTH REQUIREMENT	12
3.2 MECHANICAL INSTALLATION	14
3.2.1 STANDARD TRANSMITTER DIMENSIONS	14
3.2.2 INSTALLATION DRAWINGS FOR NON-CONDUCTIVE PIPE	15
3.2.2 FLOW SENSOR DIMENSIONS	16
3.2.3 INSTALLATION.....	16
4. ELECTRICAL CONNECTIONS	19
4.1 SAFETY INSTRUCTION.....	19
4.2 CONNECT SIGNAL & MAGNETIC FIELD CURRENT CABLE.....	19
4.3 REMOTE TYPE WIRING INSTRUCTION	20
4.4 MEF 2100 WIRING DIAGRAM	23
4.5 MEF 2100 MODBUS REGISTER DETAILS.....	23
4.6 CONNECTED TO POWER	24
4.7 LAYING ELECTRICAL CABLES CORRECTLY	24



4.8	EARTH CONNECTION.....	25
4.9	METER PARAMETER	25
5.	START UP.....	32
5.1	SWITCHING ON THE POWER.....	32
5.2	OPERATION KEY AND DISPLAY	32
5.3	METER PERFORMANCE & INDEX.....	35
5.4	SENSOR CONNECTING TYPE.....	35
5.5	SENSOR REQUIREMENT	35
5.6	DIGITAL FREQUENCY O/FREQUENCY O/P RANGE.....	35
5.7	ANALOG CURRENT O/P.....	36
5.8	DIGITAL COMMUNICATION	36
5.9	ELECTRIC ISOLATION	36
5.10	FREQUENCY OUTPUT.....	36
5.11	DIGITAL OUTPUT WIRING.....	36
5.12	DIGITAL LEVEL OUTPUT WIRING.....	37
5.13	DIGITAL OUTPUT CONNECTED WITH OPTOCOUPLER (PLC).....	37
6.	ERROR DISPOSITIONS.....	39
6.1	NO DISPLAY	39
6.2	EXCITATION MODE ALARAMING	39
6.2	EMPTY PIPE ALARAMING	39
	APPENDIX 1 : SELECTION OF EXCITING MODE (RE.).....	40
	APPENDIX 2: FUNCTION OF NONLINEAR CALIBRATION	42
	APPENDIX 3 : METER MENU.....	43
	APPENDIX 4 : HEAT MEASUREMENT INSTRUCTION MANUAL.....	46
	APPENDIX 5: MODBUS REGISTER ADDRESS DEFINITIONS	48



1. INTRODUCTION

1.1 PURPOSE OF THE MANUAL

Overview:

Welcome to the user manual for the Mial MEF(B) 2100 - Electromagnetic BTU meter. This comprehensive guide is designed to assist operators, maintenance personnel, and system integrators in understanding, installing, operating, and maintaining the Mial MEF(B) 2100 - Electromagnetic BTU meter effectively.

Objectives:

Clarification of Functionality: This manual aims to provide a clear understanding of the principles and functionality of the Mial MEF(B) 2100 - Electromagnetic BTU meter. Users will gain insights into its design, components, and how it precisely measures fluid flow.

Guidance for Installation:

Step-by-step instructions and considerations for proper installation are provided to ensure optimal performance. Safety precautions are emphasized to create a secure working environment.

Training and Familiarization:

Users will be guided through the features, controls, and indicators of the BTU meter, facilitating efficient operation. This section aims to serve as a valuable training resource for users at various experience levels.

Maintenance and Troubleshooting Assistance:

Learn about routine maintenance procedures and effective troubleshooting techniques. This manual empowers users to address common issues and perform regular maintenance to enhance the longevity of the Mial MEF(B) 2100 - Electromagnetic BTU meter.

Intended Audience:

This manual is intended for operators, maintenance personnel, and system integrators involved in the installation, operation, and maintenance of the Mial MEF(B) 2100 - Electromagnetic BTU meter. It is suitable for both novice users seeking basic guidance and experienced professionals looking for specific details.

Important Notes:

Please read through the manual carefully, adhering to safety guidelines and following instructions precisely. If any uncertainties arise during the installation, operation, or maintenance processes, seek assistance from qualified personnel or our customer service / support team.

Reference to Other Documentation:

Refer to the accompanying technical specifications document for in-depth details about the Mial MEF(B) 2100 - Electromagnetic BTU meter. Additional resources can be found on our website.

Intended use



CAUTION!

Responsibility for the use of the measuring devices with regard to suitability, intended use and corrosion resistance of the used materials against the measured fluid lies solely with the operator.



INFORMATION!

The manufacturer is not liable for any damage resulting from improper use or use for other than the intended purpose

Certification



The manufacturer certifies successful testing of the product by applying the CE marking



The manufacturer certifies successful testing of the product by applying the ISO marking

1.2 OPERATING PRINCIPLE

The MEF(B) 2100 Inline Electromagnetic BTU meter measures the thermal energy transferred by a fluid in heating or cooling systems by combining electromagnetic flow measurement and temperature sensing. It operates based on Faraday's Law of Electromagnetic Induction, where a conductive fluid flowing through a magnetic field generates a voltage proportional to its flow velocity. This flow rate is then used in the heat transfer formula:

$$\text{BTU} = \text{Flow Rate} \times \text{Density} \times \text{Specific Heat Capacity} \times (\text{Temperature inlet} - \text{Temperature outlet})$$

Here, the flow rate is measured by the electromagnetic sensor, and the temperature difference between inlet and outlet points is determined by temperature sensors, allowing the calculation of the thermal energy transfer accurately.

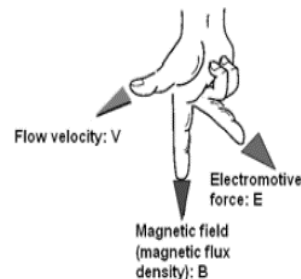
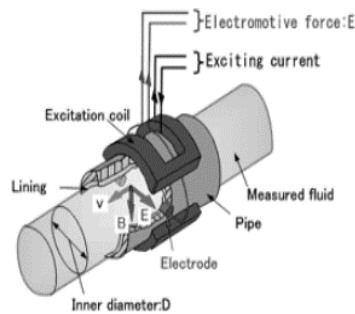



1.3 TECHNICAL SPECIFICATIONS*

Operation and performance

Flow measurement Technology

The flow measurement technology of electromagnetic flow/BTU meters are based on Faraday's law of electromagnetic induction, where the induced voltage across electrodes is proportional to the fluid velocity, allowing for accurate flow measurement.

Fluid types

Electrically conductive fluids such as water

(Hot Water, Chilled Water, Condensate Water, Domestic Water, Waste Water etc.)

Conductivity

>20us/cm

Pipe sizes

15 MM –2000 MM

Pipe materials

Metallic and Non Metallic pipes.

Flow accuracy

Standard :±0.5%

Optional: ±0.2%

Achievable with process calibration

Repeatability

Flow:±0.17%

BTU: ±0.27%

Linearity

Standard: ±0.5%

Optional: ±0.2%

Measuring range

Max 0–40 ft/s

Measurement parameters

Btu meter – Instantaneous energy rate, totalized energy, Instantaneous flow rate, totalized flow, supply temperature and return temperature

Certification

Factory calibration certification, CE, ISO

Electronics

Enclosures

Aluminium

Use weather proof enclosure while installing the transmitter outside

Enclosure IP rating

IP 65

EEPROM Memory

Yes

Power supply

24 VDC/2A

Use 2-amp SMPS when employing AC power

Ambient temperature

32°F to 140°F (0°C to 60°C)

Relative Humidity

5– 95% RH

Standard Analog outputs

Flow meter– 4–20 mA

Output programmed for current flow rate. 500 Ω maximum load,

Btu meter– 4–20 mA

output programmed for current flow rate or current energy rate.500 Ω maximum load

Pulse Outputs

Flow Meter– Pulse

Programmed for Flow Consumption , Contact pulse Duration –0.1~300 ms

Btu meter – Pulse

Programmed for Enery Consumption or Flow consumption , Contact pulse Duration –0.1~300 ms

Network Connection

Modbus RTU RS485

Cable

10M

Flow tube specification

Coil material

Pure Copper

99% copper (Cu) content, excellent electrical conductivity, corrosion resistance

Process connections

Standard: ANSI 150 flanges

Optional: ANSI 300 flanges

Operating temperature

14°F to 248°F (–10°C to 120°C)

Nominal Pressure

Standard: 1.6 Mpa

Optional: 2.5 Mpa, 4.0 Mpa, 5Mpa

Flow Tube

SS 304

Electrode Material

Standard: SS 316L

Optional: Hastelloy, Titanium, Tantalum,

Flow tube : IP68

Tramsmmitter : IP 65

Liner

Standard: PTFE

Optional: Ebonite,
Polyebonite,

Flange

Standard: Carbon Steel

Optional: Stainles steel

Mountings

Flanged flow tube

IP rating

Energy measurement

Temperature sensor

PT1000

22°F to 392°F (-30°C-200°C)

Wetted insertion thermowell

Cable

10 M

**Specifications are subject to change without prior notice.*



1.4 SUPPLEMENTARY ACCESSORIES THAT COULD BE NEEDED

1.4.1 GROUNDING RINGS

Grounding rings may be needed when meters are installed in non-metallic pipes or lined pipes. Placing these rings before and after the meter helps to reduce electrical interference, allowing the meter to function accurately. Mial Instruments provides these grounding rings as an optional accessories.

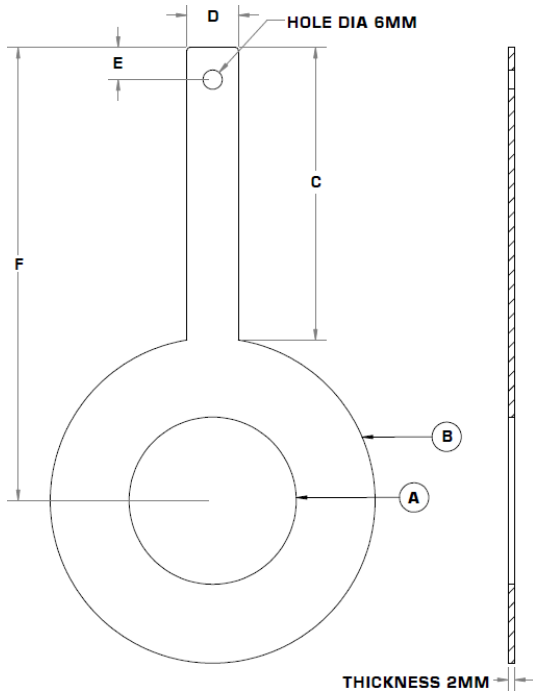

GROUNDING RING SIZES						
ALL DIAMENSIONS ARE FOR FLANGE 150#						
SIZE (MM)	A (ID)	B (OD)	C	D	E	F
15	18	40	50	16	10	70
20	23	42	60	16	10	81
25	26	62	60	16	10	91
32	32	63	60	16	10	91.5
40	40	80	60	16	10	100
50	52	101	60	16	10	110.5
65	63	104	70	20	10	122
80	80	130	70	20	10	135
100	104	158	75	20	10	154
125	130	187	75	20	10	168.5
150	158	217	75	20	10	183.5
200	206	267	75	20	10	208.5
250	260	328	75	20	10	239
300	310	375	85	20	10	272.5

ALL DIAMENSIONS IN MM









CAUTION!

Mandatory to loop between the grounding rings by using a proper wire and connect the end of the wire to a ground source in the DDC panel. (please add this sentence in the above paragraph).



2. DEVICE DESCRIPTION

2.1 SCOPE OF DELIVERY

-  **INFORMATION!**
Do a check of the packing list to make sure that you have all the elements given in the order
-  **INFORMATION!**
Inspect the packaging carefully for damages or signs of rough handling. Report damage to the carrier and to the local office of the manufacturer.
-  **INFORMATION!**
The field device will arrive in one standard cartons. The standard carton contains one small corrugated box containing Transmitter Unit,. Also, the standard carton box contains Flow Tube, Supply Temperature Sensor, Return Temperature Sensor, Product documentation, Test Certificates, Allen key & bolts sets
-  **INFORMATION**
The MEF(B) 2100 transmitters and sensor bodies are components of a uniquely calibrated system and must be installed together as per the serial number. Mixing components from other systems will result in significant calibration errors. The transmitter serial number can be found on the sticker on the side of the electronics enclosure, and the sensor serial number is located on the sticker on the sensor body.
-  **INFORMATION!**
Grounding Ring will be provided only if the pipe material is Non-Metallic & will be charged additional
-  **INFORMATION!**
Mandatory to loop between the grounding rings by using a proper wire and connect the end of the wire to a ground source in the DDC panel.

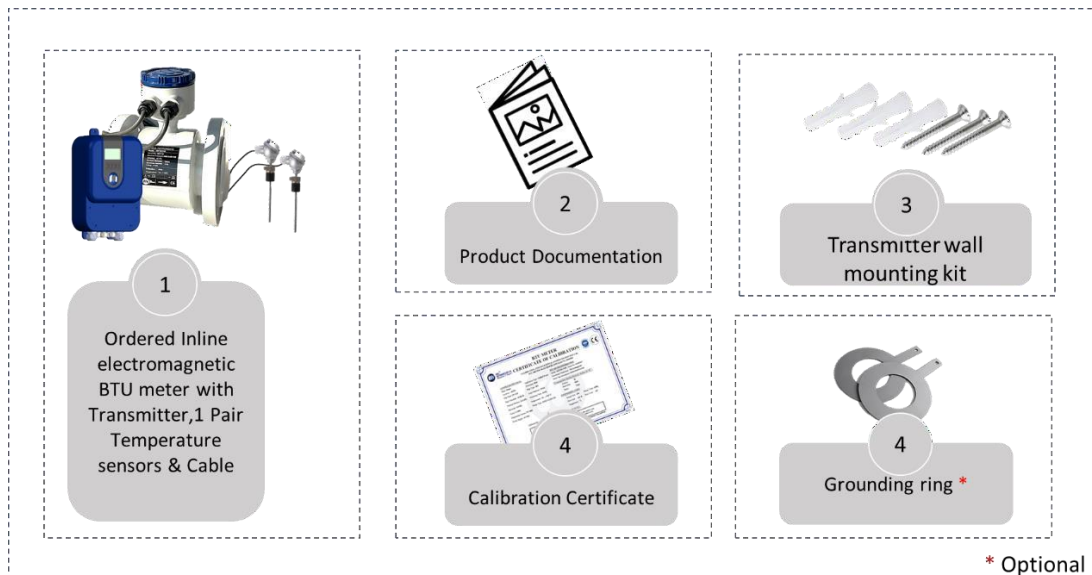

2.2 NAMEPLATES



INFORMATION!

Look at the device nameplate to ensure that the device is delivered according to your order. Check for the correct supply voltage printed on the nameplate

NAMEPLATE FOR THE TRANSMITTER

Electromagnetic heat meter

Model: MEF(B) 2100
 Serial No: XXXXXXXX
 Nominal Diameter: DN XXXX Factor: XXXXXX
 Nominal pressure : ANSI 150# Accuracy: 0.5%
 Protection: IP65 Output: 4-20 mA
 Power Supply: 24VDC
 Communication: RS 485 MODBUS

MIAL[®] INSTRUMENTS PVT. LTD.
Measuring & Beyond
MIAL INSTRUMENTS

NAMEPLATE FOR THE FLOW TUBE

MIAL INSTRUMENTS



Model: MEF(B) 2100



Serial No: XXXXXXXXXXXX

Nominal Pressure : ANSI CLASS 150#
Accuracy: 0.5%

Nominal Diameter: DN XXX
Electrode Material: XXXXXX
Lining : XXXXX

Protection : IP68
Temperature : -10....+120°C

→



→



MIAL[®] INSTRUMENTS PVT. LTD.
Measuring & Beyond

→



3. INSTALLATION

3.1 SITE SELECTION

When selecting a site for a BTU meter installation, prioritize accessibility for installation and maintenance. Consider environmental factors like temperature and humidity as per guidelines. Ensure the flow profile is stable and the pipe is in good condition. Safety and ease of access for personnel should also be taken into account to optimize meter performance and longevity.

3.1.1 BASIC RECOMMENDATIONS

In general guidelines, it's recommended to find a location where the pipe has the longest straight segment with a clear run. This ensures smooth laminar flow of the fluid through the meter, which is crucial for accurate measurement. A longer clear run of pipe minimizes disturbances and turbulence that could affect the meter's performance. This approach helps optimize the meter's accuracy and reliability by providing a stable flow profile for measurement.

3.1.2 FLOW DIRECTION

The Mial MEF(B) 2100 BTU meter should be installed ensuring the arrow indicated on the meter points in the direction of flow. When correctly installed, as illustrated, the arrowhead should align with the flow direction. The transmitter display will indicate positive values corresponding to the flow direction indicated by the arrow. If the fluid flows in the opposite direction to the arrow, the display will show negative readings reflecting the reverse flow direction.

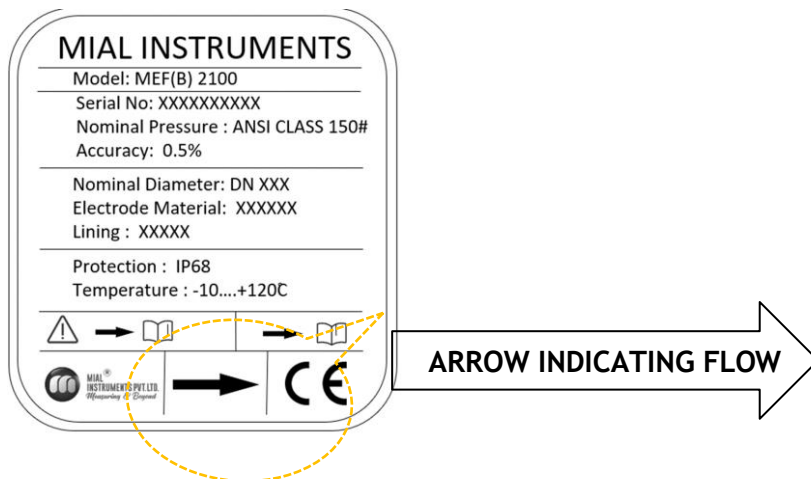

3.1.3 INSTALLATION OF REMOTE MOUNT TRANSMITTER

Installing a remote mount transmitter involves placing the unit at a distance where the display is easily visible to the user. It should be positioned away from equipment that may generate electrical interference. The standard cable length from the flow tube to the transmitter becomes 10 meters and it can't be cut or extendable at the site. For the outdoor installation mandatory to provide a non-metallic FRP/GRP enclosure



3.1.4 STRAIGHT LENGTH REQUIREMENT

The diagrams below demonstrate the minimum straight length necessary to ensure accurate readings from the BTU meter. Having additional straight length beyond this minimum requirement offers additional advantages, such as enhanced measurement precision and reduced potential for turbulence or flow disturbances that could affect meter performance. Therefore, maximizing the straight length of the pipe where the BTU meter is installed can contribute to optimizing the overall effectiveness and reliability of the measurement process.

SLOP & VERTICAL LINES

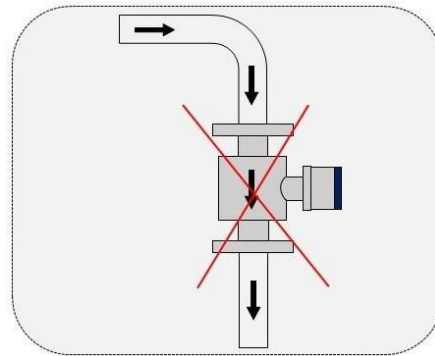
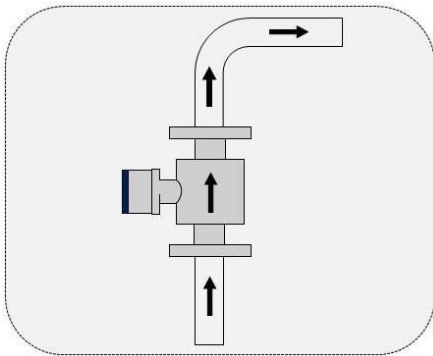

Install at the rising direction

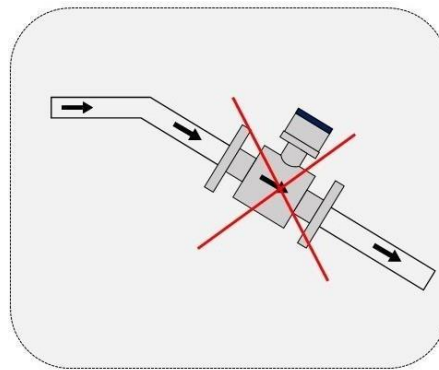
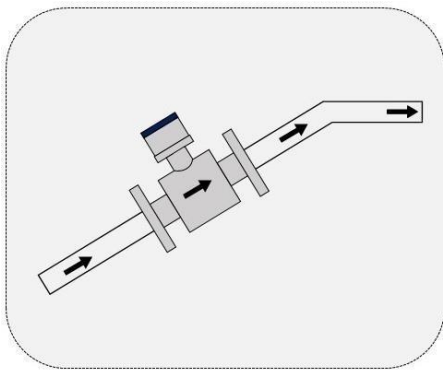

OPEN FEED OR DISCHARGE

Install at the rising direction

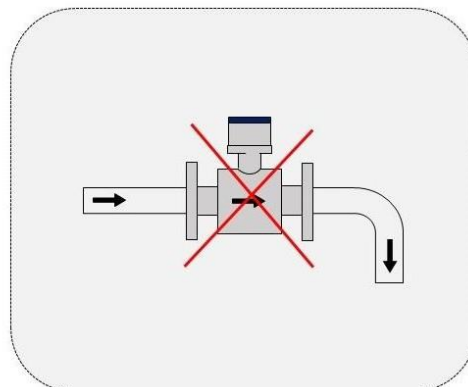
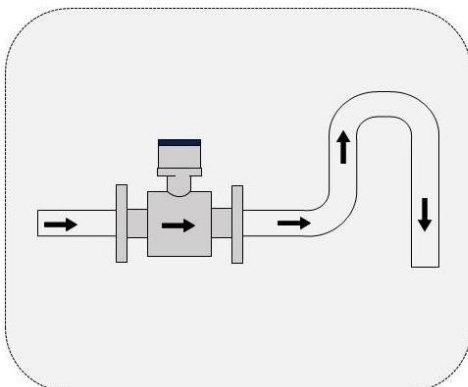

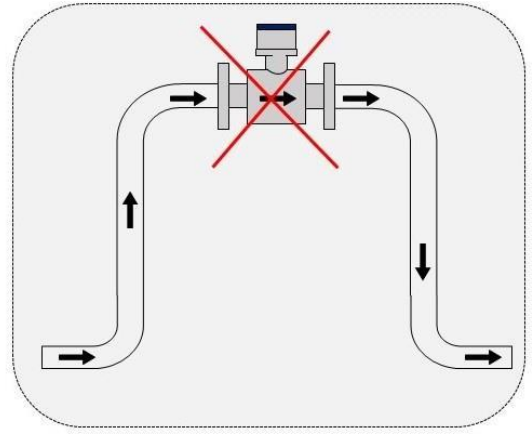
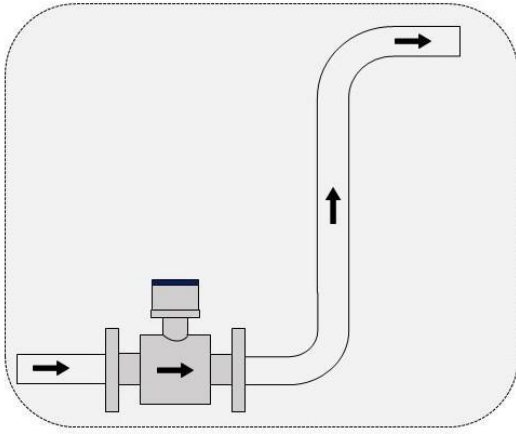

Install at the lowest point when used in open drain pipe

CONTROL VALVE

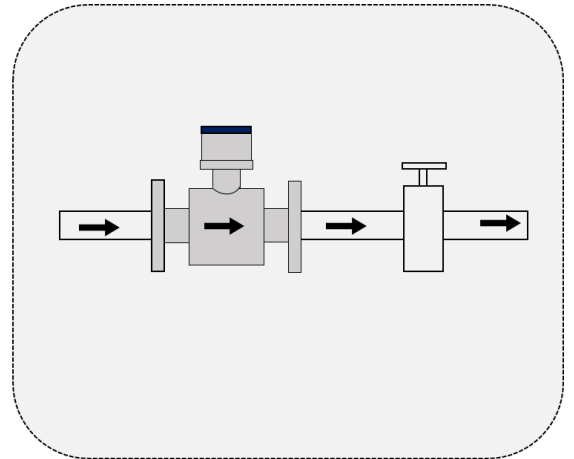
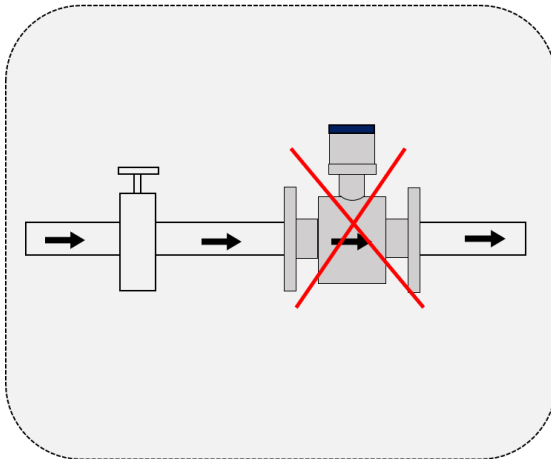

Don't install it at the exit of the valve, install it at the entrance of the valve

POSITION OF PUMP

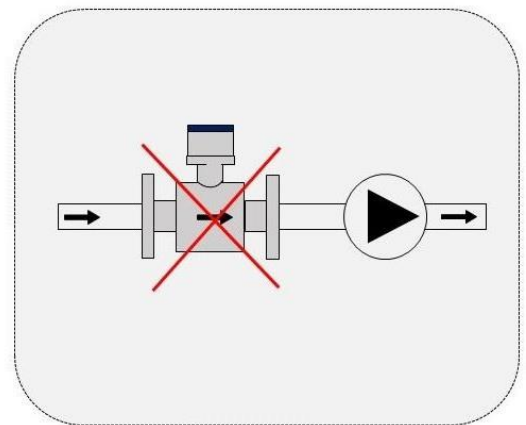
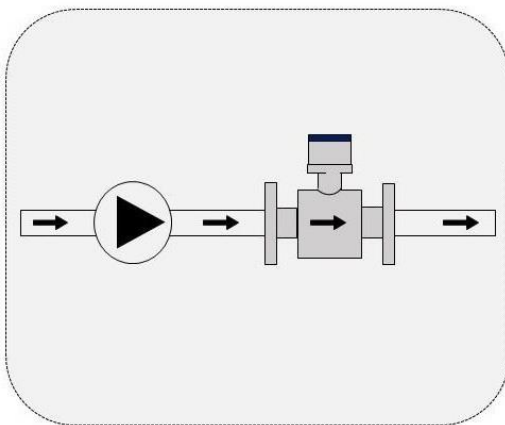

Don't install it at the entrance of the pump, install it at the exit of the pump



DOWN GOING PIPELINE OVER 5 M /16 FT LENGTH

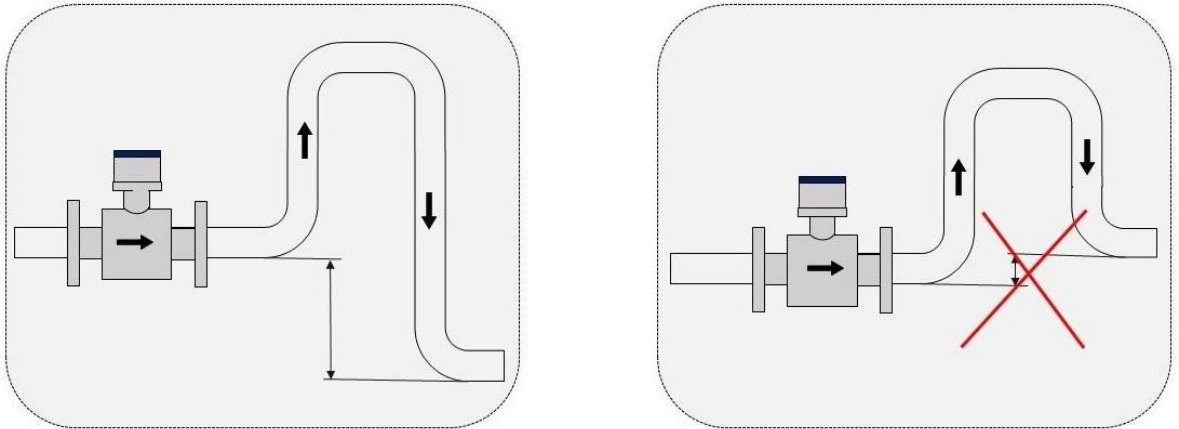

The downstream of BTU meter when the drop is more than 5 m

3.2 MECHANICAL INSTALLATION



IMPORTANT NOTE!

MEF(B) 2100 transmitters and sensor bodies are two parts of one uniquely calibrated system and must be installed together as per the serial Number . Mixing components from other systems will result in significant calibration errors.

3.2.1 STANDARD TRANSMITTER DIMENSIONS





3.2.2 INSTALLATION DRAWINGS FOR NON-CONDUCTIVE PIPE

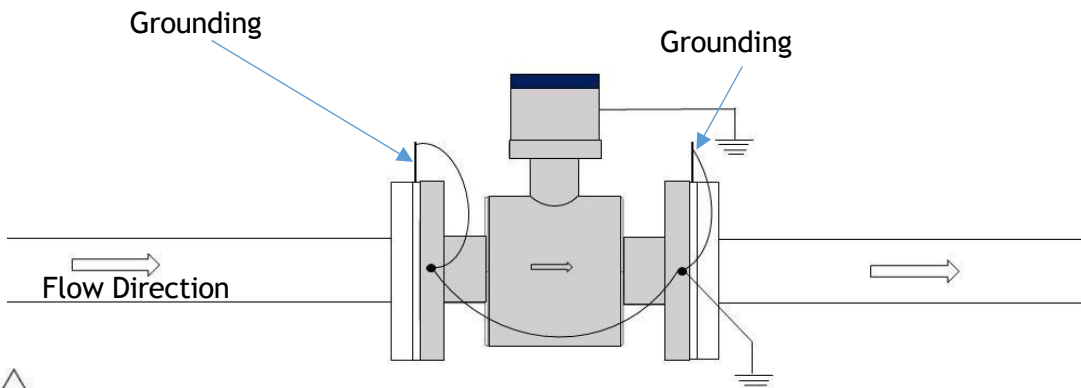

CAUTION

Make sure to connect the earth wires like the picture shows. If you don't, the meter might not work right.

INSTALLATION STEPS



WARNING!

Only trained workers should install this product, and they must follow all the rules for buildings.

1. Clean all flange surfaces well, making sure to remove any old gasket material or adhesive
2. Check all flange surfaces for any bending, dents, or other problems that might stop a good seal.
3. Use new bolts, nuts, and strong washers. Before putting them in, apply lubricant to the bolt threads, nuts, washer sides, and under the bolt head. This helps spread pressure evenly on the seal. Be careful not to get any lubricant on the liner or gasket.
4. Place the new gasket in the middle of the liner surface. Make sure the gasket doesn't stick out into where the liquid flows.
5. Use a torque wrench to tighten the bolts in three stages: first 30%, then 60%, and finally 100%. Tighten them in a repeating pattern.



3.2.3 FLOW SENSOR DIMENSIONS

ANSI CLASS 150 FLANGED SENSOR OVERALL DIMENSION

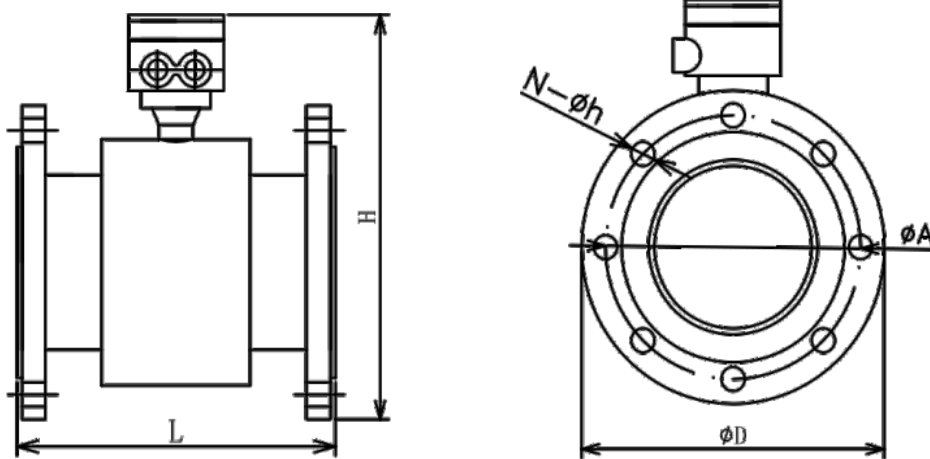

PIPE SIZE	L	D	A	N- Ø h	H
DN 15	200	89	60.5	4-Ø15.7	217
DN20	200	99	69.9	4-Ø15.7	217
DN25	200	108	79.3	4-Ø15.7	220
DN32	200	118	88.9	4-Ø15.7	230
DN40	200	127	98.6	4-Ø15.7	240
DN50	200	152	120.7	4-Ø19.1	255
DN65	200	178	139.7	4-Ø19.1	280
DN80	200	190	152.4	4-Ø19.1	285
DN100	250	229	190.5	8-Ø19.1	315
DN125	250	254	215.9	8-Ø22.4	340
DN150	300	280	241.3	8-Ø22.4	370
DN200	350	343	298.5	8-Ø22.4	430
DN250	450	406	362	12-Ø25.4	495
DN300	500	483	432	12-Ø25.4	558
DN350	550	533	476.3	12-Ø28.4	608
DN400	600	597	540	16-Ø28.4	674
DN450	600	635	578	16-Ø32	718
DN500	600	699	635	20-Ø32	775



3.2.4 INSTALLATION

Installation of this product should be carried out by qualified professionals, ensuring compliance with all relevant local, state, and federal building codes. Begin by thoroughly cleaning all flange surfaces to remove any old gasket material and adhesive residue. Inspect the flange surfaces for any warping, pitting, or imperfections that could affect the seal. Use new bolts, nuts, and hardened washers, and lubricate them to ensure even stress distribution during installation. Be careful to avoid getting any lubricant on the liner .

INSTALLATION DIAGRAM

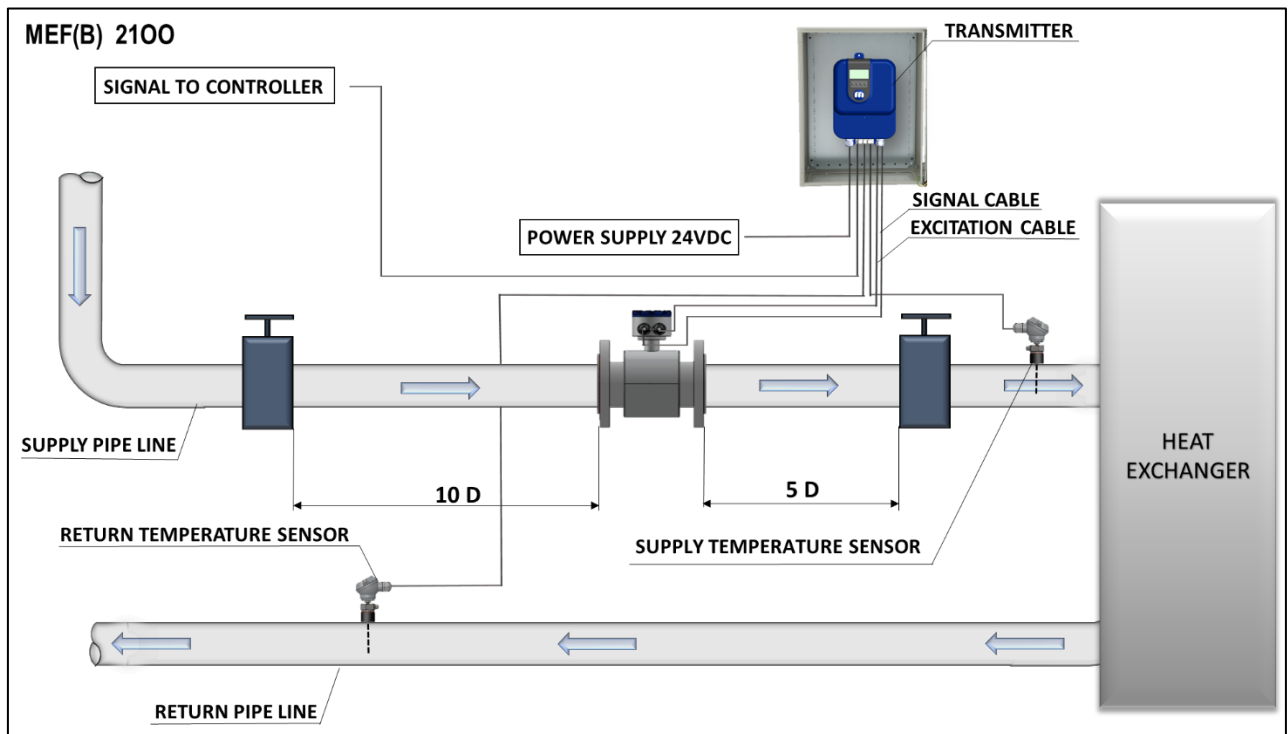

To ensure electromagnetic BTU meters work correctly, install the flow sensor head at the top of a horizontal pipe at the 12 o'clock position. The pipeline must be pressurized and filled entirely with clean water, without any air or particles. Air and particles act as insulators, disrupting the meters' electromagnetic induction and impairing their function. For vertical pipes, install the meter so water flows from bottom to top for optimal performance.



THERMOWELL INSTALLATION



IMPORTANT NOTE

It is crucial to ensure that no dirt or foreign materials enter the thermowells, as their presence could impact the system's thermal response.

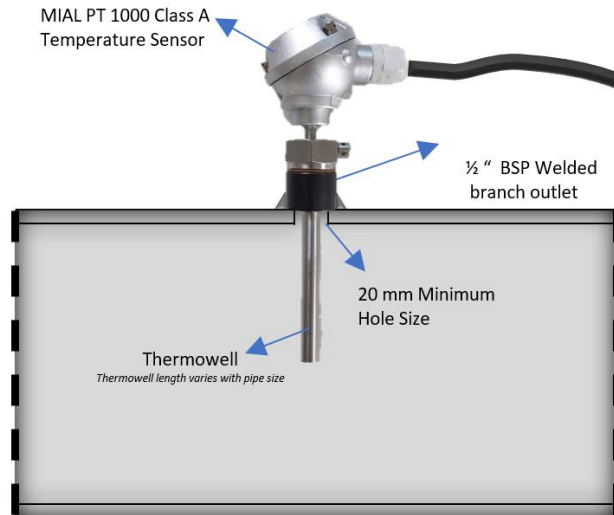

IMPORTANT NOTE!

3.2.3.1 The length of the thermowell varies depending on the pipe size.

3.2.3.2 Avoid using additional bushings to ensure the tip of the thermowell is properly inserted into the flow stream.

Temperature Sensor Installation

The BTU meter comes with factory-matched temperature sensors, identified by serial numbers. These sensors, labeled as SUPPLY and RETURN, should be used exclusively with the designated BTU meter. Consult MIAL Factory before considering any alternative temperature sensors.

For proper installation, apply a thin layer of thermal compound to the temperature sensor. Carefully insert the sensor into the thermowell until it reaches the bottom of the cavity, then gently secure it with the retainer nut. Avoid over-tightening the nut, as the thermowell already seals the plumbing system. The nut's primary function is to ensure the sensor maintains contact with the bottom of the thermowell cavity.



4 ELECTRICAL CONNECTIONS

4.1 SAFETY INSTRUCTIONS



DANGER!

Only when power is switched off, we can do all the work about electrical connections. Please pay all attention to the power supply on the name plate!



DANGER!

Observe the national regulations for electrical installations!



DANGER!

For devices used in hazardous areas, additional safety notes apply; please refer to the Ex documentation.



WARNING!

Observe without fail the local occupational health and safety regulations. Any work done on the electrical components of the measuring device may only be carried out by properly trained specialists.



INFORMATION!

Look at the device nameplate to ensure that the device is delivered according to your order. Check for the correct supply voltage printed on the nameplate.



INFORMATION!

Connect the cable on connector with similar numeral marking

4.2 CONNECT SIGNAL AND MAGNETIC FIELD CURRENT CABLE



Danger !

Only when power is cut off we can you connect signal and magnetic field current conductor.



Danger !

The equipment must be grounded in accordance with regulations so as to protect the operator from electrical shock.



Danger !

In case that equipment be used in explosion danger areas, special notes are given to explosion-proof instructions for safety tips.



Warning !

Please strictly observe local occupational health and safety regulations. Only those who have got properly trained are allowed to operate on the electrical equipment



4.3 REMOTE TYPE WIRING INSTRUCTION

SIGNAL LINE DISPOSE

When meter works with sensors and conductivity of measuring flow is larger than $50\mu\text{S}/\text{cm}$, under this circumstance, PVVPB $2*0.12*280\text{mm}^2$ model cable (metal shielded signal line covered with PVC) can be used as communication cable for flow signals. The length of signal cable should be less than 100m. Signal lines have to be connected to sensors that were assembled by producers. The meter can output equivalent level of exciting shielded signal voltage so that interference on flow measurement signals can reduced by means of decreasing the distributed capacitance of communication cable. When conductivity of measuring flow is less than $50\mu\text{S}/\text{cm}$ or signals are transferred in remote distances, under this circumstance, double-conductor and double-shielded signal line at equivalent level of voltage can be used. For example, special STT3200 cable or BTS model signal cable (triple-shielded) can be used for signal communication.

EXCITING CURRENT CABLE

Two conductor and insulating rubber- covered cables can be used as exciting current lines. Suggested model is RVVP $2*0.12*250\text{mm}^2$. Length of exciting current line should be equal to the length of signal cable. When the model STT3200 cables are used for exciting current, exciting current line and signal line can be put together as one line.

METER TERMINAL WIRING

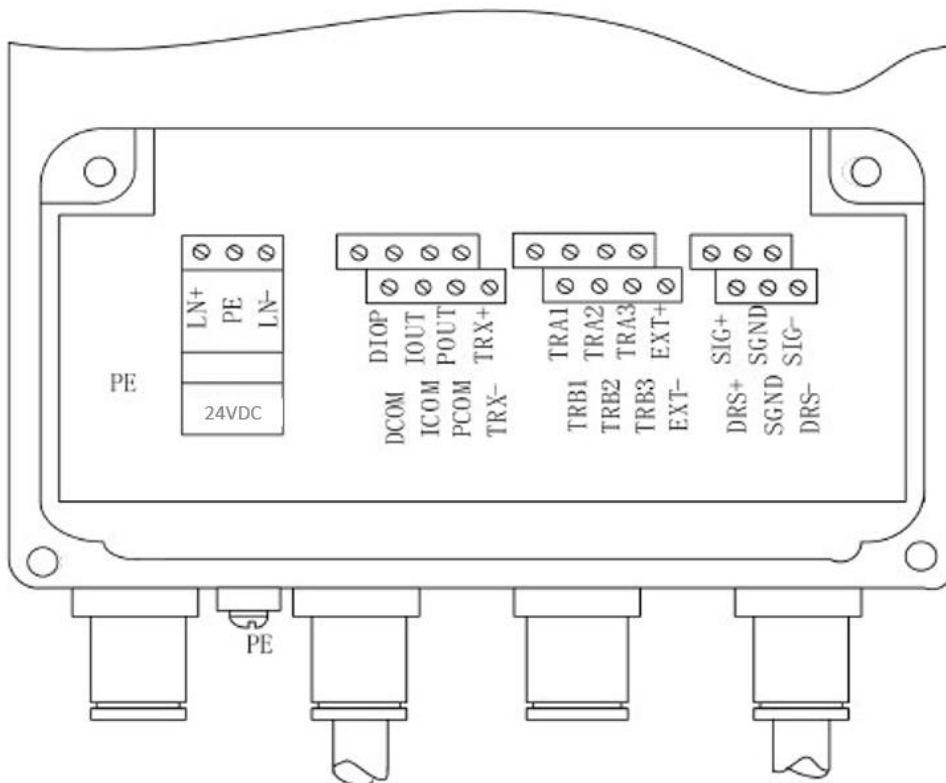

TRA1	Entry Temperature Input	TRA2	Entry Temperature Input
TRA3	Entry Temperature Input	TRB1	Outlet Temperature Input
TRB2	Outlet Temperature Input	TRB3	Outlet Temperature Input
SIG +	Signal 1	SGND	Signal Ground
SIG-	Signal 2	DRS +	Exciting Shielding 1
DRS-	Exciting Shielding 2	MTDR	Reserve
EXT +	Exciting Current +	EXT-	Exciting Current-
POUT	Frequency Output +	PCOM	Frequency Output Ground
IOUT	Current Output +	ICOM	Current Output Ground
TRX-	Communication Interface (RS485-B)	TRX+	Communication Interface (RS485-A)
LN-	24 VDC Power Supply Input	LN+	24 VDC Power Supply Input
DIOP	Reserve	DCOM	Reserve

4.3.2 FREQUENCY AND PULSE OUTPUT LINE

The figures below show frequency and pulse output connection with power supply and load. Diode should be added when using inductive load

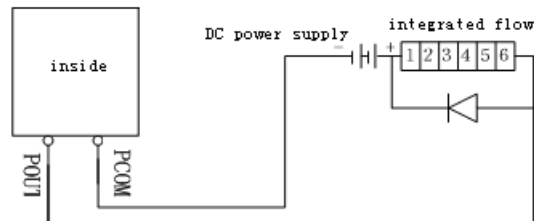

External power supply connecting with electronic counter

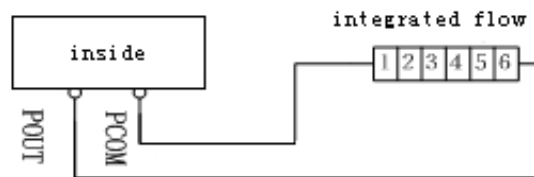

Internal power supply connecting with electronic counter

Current Output Wiring

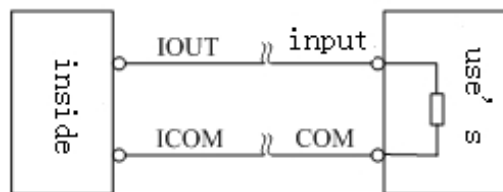

OC Door Connection

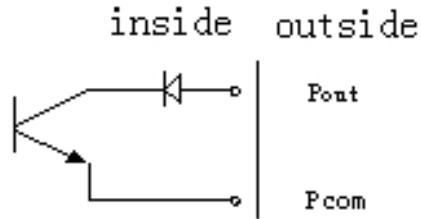

THE GROUNDING REQUIREMENTS WHEN INSTALLING CONVERT

Convert shell's earth terminal PE should use grounding copper wire which is less than 1.6mm². The ground resistance from convert's shell to ground should less than 10Ω. First, purple copper tube should be cut into 1700 mm long (the copper tube can be lengthened according to the need) to make the nail buried 1500 mm into the ground(Note : when burying nail, sprinkling a layer of broken charcoal at the top of nail, and then saline irrigation).Then, 4mm² purple copper wire should be welded to the nail. At last, connecting ground wire to convert's flange, ground ring and pipeline's flange. It is shown in figure

Note: Stainless steel must be used when fixing ground screws, spring washers and flat washers.

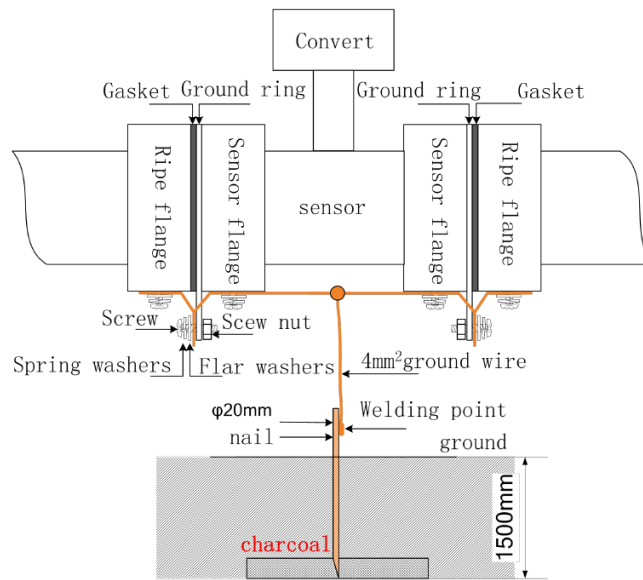



4.4 MEF(B) 2100 WIRING DIAGRAM AND MODBUS REGISTER DETAILS

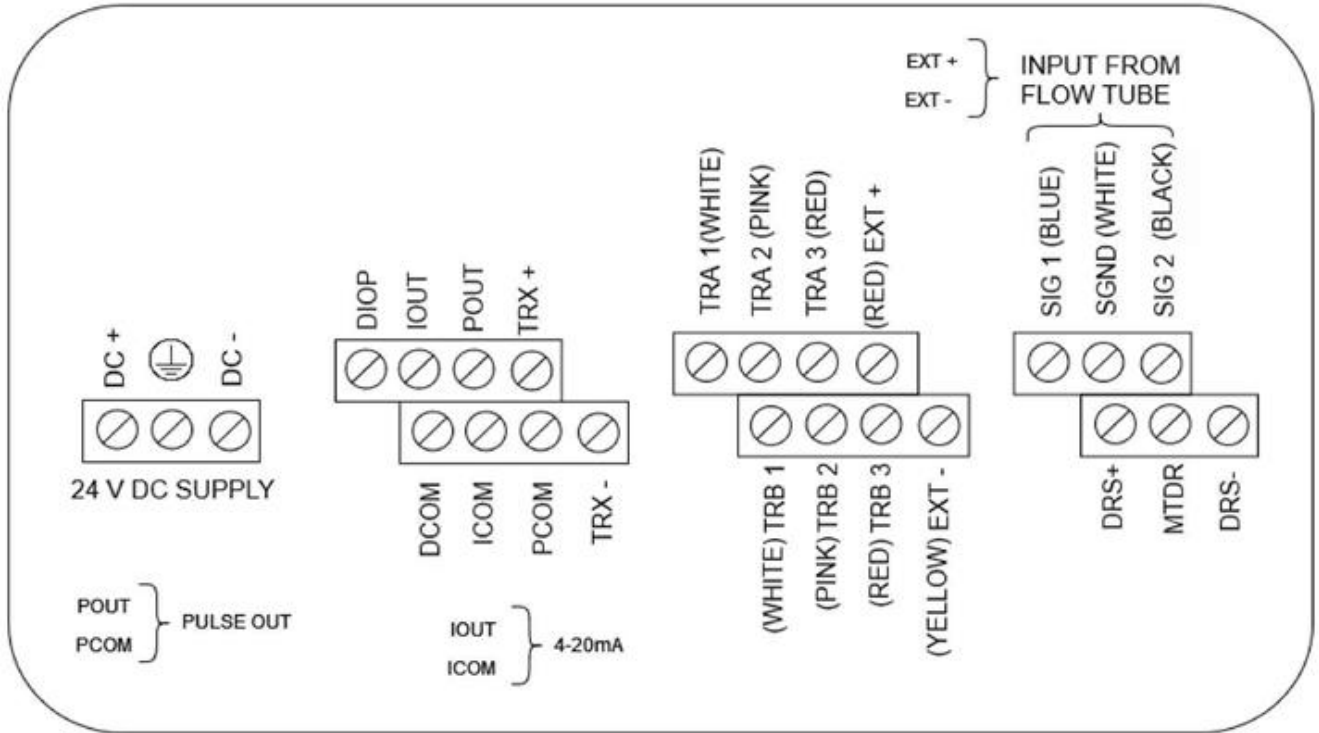

MEF(B)2100 (Remote) Flow Meter Wiring Diagram

4.5 MEF(B) 2100 MODBUS CONFIGURATION DETAILS OF BTU METER TO BMS

Function Code	Details	Register Address	Modbus Register	Register Type
04 : Input Register	Supply Temperature	4141	34141	Decimal/ Integer
	Return Temperature	4142	34142	Decimal/ Integer
	Energy Rate	4147	34147	Swapped F.P
	Energy Total	4143,4144	34143,34144	Decimal/ Integer
	Flow Rate	4113	34113	Swapped F.P
	Flow Total	4121, 4122	34121, 34122	Decimal

*N.B:- Supply Temperature = [34141] /10

Return Temperature = [34142] /10

N.B:-Energy Total = 65535[34143] +[34144]

Parity	: None
Word Length	: 8
Stop Bit	: 1



$$\text{Flow Total} = 65535 * [34121] + [34122]$$

{where; 34143,34121 – High Position registers

34144,34122- Low Position registers.}

Note: If your BMS register address starts from '0', please decrement '1' value from every register. Example: Supply temperature register is 34141 then it should be configured as 34140..

4.6 CONNECTED TO POWER



It is mandatory to provide an individual 24 VDC, SMPS (Switch Mode Power Supply) for energizing the BTU meters. Additionally, it is essential to pull three-core wires (DC+, DC-, and ground) for the 24 VDC input power supply. As these are electromagnetic BTU meters, a proper input power supply with an appropriate ground is crucial for their correct operations



Danger !

The equipment must be grounded in accordance with regulations so as to protect the operator from electrical shock.



Don't use bolts that hold the pipes together to make electrical connections. These bolts might not connect well because of paint or grease. Instead, use the special earth connections on the flange.

4.7 LAYING ELECTRICAL CABLES CORRECTLY

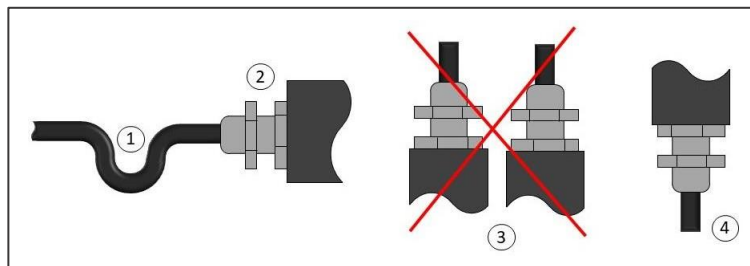

Keep the housing safe from dust and water

- i. Create a loop with the cable just before it reaches the housing.
- ii. Securely tighten the screw connection at the cable entry.
- iii. Always mount the housing with the cable entries facing downward.
- iv. Seal any unused cable entries with a plug.



4.8 EARTH CONNECTION



MEF(B) 2100 BTU meters detect small Electrical signals from electrodes when conductive fluid flows through their magnetic field, but electrical noise can interfere. To minimize noise, ensure the pipe, fluid, BTU meter body, and transmitter are all connected to the same earth ground with the earth cable as short as possible.

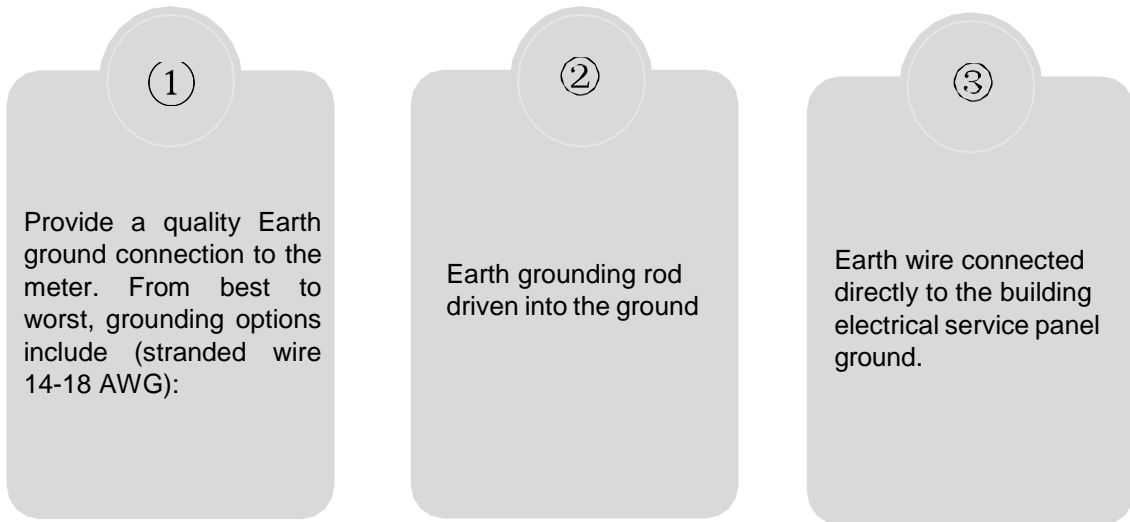

4.9 METER PARAMETERS

4.9.1 FLOW PARAMETERS

WORKING MODE

MEFB Series have three working modes: Heat Meter working mode, Cold Meter working mode and Heat & Cold Meter working mode. Heat Meter working mode: default mode, measure on heat. “H” stands for heat. Cold Meter working mode: measure on cold. “R” stands for cold. Heat & Cold Meter working mode: measure on both heat and cold. Measuring results display separately.

MEASURING PIPE SIZE

Cold and Heat meter sensor pipe size scope of MEFB Series is 10-2000mm. 0, 15, 20, 25, 32, 40, 50, 65, 80, 100, 125, 150, 200, 250, 300, 350, 400, 450, 500, 600, 700, 800, 900, 1000, 1200, 1400, 1600, 1800 and 2000.



FLOW UNIT

Flow units included m3/h.

HEAT UNIT AND COLD UNIT

Displayed heat unit includes MJ/h、 GJ/h、 KWh/h、 MWh/h

MEASURED DAMPING TIME

Measured damping time means filter time. Long measured damping time can enhance the stability of flow display and output signal and be applied for gross add up of pulse flow. Short measured damping time means quick respond to measurement and be applied in production control. Measured damping time setting is by choosing.

FLOW DIRECTION CHOOSING

When doing debugging, if the flow direction is not consistent, users don't need to change connection of exciting and signals lines, just to reset the flow direction parameter.

FLOW ZERO-POINT CORRECTION

Make sure the sensor is full and the fluid is in stationary state when doing the flow zero-point correction. Flow zero-point is shown as velocity of flow, unit is mm/s. Zero-point correction displayed as below:

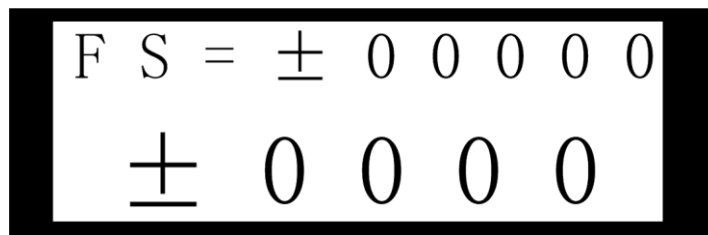

Upper small characters: FS means measured zero-point; Lower large characters: corrected flow zero-point.

When FS display is not “0” , do correction to make FS display “0” . Note: if correct lower line character and FS increases, change the “+,-” in lower line to make sure FS display to be zero. The corrected flow zero-point is the compound value of sensor, and should be recorded in sensor list and label. The unit is mm/s, and the sign is in opposite with corrected value. Cold and Heat meter sensor pipe size scope of MEFB Series is 10-2000mm.

10, 15, 20, 25, 32, 40, 50, 65, 80, 100, 125, 150, 200, 250, 300, 350, 400, 450, 500, 600, 700, 800, 900, 1000, 1200, 1400, 1600,1800 and 2000.

SMALL SIGNAL ELIMINATION POINT

Small signal elimination point setting is showed by flow. When small signal iseliminate, only the velocity of flow, elimination flow, percent display and signaloutput are displayed.



TEMPERATURE GAPS SIGNAL ELIMINATION

When the temperature gaps of the flow entry temperature and flow outlet temperature is less than the setting temperature, the meter will not calculate.

FLOW INTEGRATING UNIT

9 bit calculator is applied and the upper limit is 999999999. Unit is m³ and flow equivalent is 0.001m³, 0.010m³, 0.100m³, 1.000m³.

HEAT AND COLD INTEGRATING UNIT

9 bit calculator is applied to Heat Meter and the upper limit is 999999999. Heat integrating unit is MJ、GJ、KWh、MWh. Heat Equivalent : 0.001MJ、0.010MJ、0.100MJ、1.000MJ

0.001GJ、0.010GJ、0.100GJ、1.000GJ 0.001 KWh、0.010 KWh、0.100 KWh、1.000 KWh 0.001 MWh、0.010 MWh、0.100 MWh、1.000MWh measurement forbidden. If the function is applied as “Forbidden” , no output for heat and cold measurement and only flow velocity is able to display. If the function is applied as “Allowed” , all other functions work as intended. As default, if the flow is reverse, heat and cold integrating will not be measured

4.9.2 OUTPUT PARAMETERS

CURRENT OUTPUT MODE

There are six current output modes: flow output, heat output, cold output, heat & cold output, status output and flow direction output. Flow output: current is output as instant flow percent, the percent means the flow percent. Heat output: current is output as instant heat percent, the percent means the heat percent. Cold output: current is output as instant cold percent, the percent means the cold percent. Heat Cold output: current is output as instant heat or cold percent, the percent means the heat or cold percent. status output: current is output as instant heat or cold status. When in heat status, current output is 20mA. When in cold status, current output is 4mA. Flow direction output: current is output as the flow direction. When the direction is reverse, the current is 20mA. When in the positive direction, the current is 4mA.

RANGE SETTING OF FLOW, HEAT AND COLD

Meter range setting is to set the flow upper limit, and the lower limit is set to “0” automatically. The meter range setting decides the range of the meter, and also decides the meter percent display, meter current and correspondence between frequency output and flow, heat and cold. Meter percent display value = (measured flow value / meter range) * 100% Meter current output value = (measured flow value / meter range) * 20mA + 4mA Meter frequency output value = (measured flow value / meter range) * frequency full range.

IMPULSE MODE

There are sixteen impulse modes: flow impulse Ltr, flow impulse m³, heat impulse MJ, GJ, KWh, MWh, cold output MJ,GJ, KWh, MWh,, cold & heat output MJ,GJ, KWh, MWh, old & heat status and flow direction output.

Frequency output mode: frequency output is continuous square wave, and frequency value corresponds with the percentage of flow. Detailed, refer to 2.4. Impulse output mode: pulse output is a rectangular wave pulse train, and each pulse represents there is a flow equivalent in the pipe. The impulse equivalent is set by “impulse output type” parameter and “output impulse coefficient”

parameter. Impulse output mode can be used in gross accumulation and generally, connected to the integrating meter. Cold & heat status output: when impulse output stands for the cold & heat status,



heat is low level and cold is high level. Flow direction output: when impulse output stands for flow direction, forward is low level, and the reverse is high level.

UPPER LIMIT OF FREQUENCY OUTPUT

The meter output frequency corresponds to the flow percent output (do not corresponds to heat and cold), the range can be chosen for 1~5000. The formula is as below:

$$\text{Meter frequency output} = (\text{measured flow value} / \text{flow range}) * \text{frequency full range}$$

OUTPUT IMPULSE COEFFICIENT

Impulse coefficient is impulse equivalent, the range is 0.001~59.999. The unit is them same with the chosen impulse output type unit, and is used to measure impulse output.

WIDTH OF OUTPUT IMPULSE

Output impulse is effective when the output is low level, the impulse width is 0.3~499.9ms. Impulse width and maximum output pulse number correspondence table

No.	Impulse width (ms)	Maximum output pulse number per hour (p/h)
1	1	1800000
2	5	360000
3	10	180000
4	50	36000
5	100	18000
6	200	9000
7	500	3600

4.9.3 SENSOR PARAMETER

SENSOR COEFFICIENT

Sensor coefficient is the calibration coefficient of the flow meter which is obtained by the factory and sealed to the sensor label. The coefficient should be set in MEF(B) parameter list.

EXCITATION MODE CHOOSING

There are two excitation modes: frequency 1/10 (mode 1) and frequency 1/12 (mode 2). Mode 1 is usually applied to small caliber and mode 2 is applied to big caliber. Select mode 1 first and if the meter velocity zero-point is too high, then select mode 2.

※Note: the chosen excitation mode should be determined by excitation calibration mode.

SENSOR CODE 1 AND 2

Sensor code is used by the manufacturer to record the sensor.

INSTALLATION PLACE OF METER

If the sensor is installed in pipe entrance, choose “inlet” ; if the sensor is installed in pipe outlet, choose “export” , otherwise, there will be an error.



4.9.4 TEMPERATURE PARAMETER

INITIAL TEMPERATURE OF HEAT METER AND COLD METER

If the temperature is lower than the initial setting temperature, the meter will not calculate the heat or cold.

WORKING PRESSURE CHOOSING

0.6 MP or 1.6 MP can be chosen according to CJ128–2007.

ENTRANCE AND OUTLET TEMPERATURE ZERO AND TEMPERATURE CALIBRATION

Pt1000 RTD three-wire bridge connection method is applied, and detailed calibration methods refer to Appendix 4.

4.9.5 ALARMING PARAMETER

EMPTY PIPE ALARMING ALLOWANCE

Empty pipe alarming is applied to MEFB and no additional pole is needed. If the function is chosen, if the liquid is less than the pole, the empty pipe can be detected. Then the analog output, digital output and flow display become zero.

EMPTY PIPE ALARMING THRESHOLD

When the liquid is full of the pipe, the empty pipe alarming function is applied. The upper line of the display shows the actual tested conductance, the lower line of the display shows the empty pipe alarming threshold. The empty pipe alarming threshold should be set based on tested conductance and 3-5 times of the tested conductance. The alarming, the “MT” is displayed.

EXCITATION MODE ALARMING

The function is in effective when the parameter is set as “allowed” and when alarming, “SY” is displayed.

4.9.6 LINEAR CALIBRATION PARAMETER

ALLOWANCE FOR FLOW CALIBRATION

The parameter is used to choose whether the nonlinear calibration is applied. “Allowance” means that calibration is applied, and “Forbidden” means that calibration is not applied. Empty pipe alarming is applied to MEFB and no additional pole is needed. If the function is chosen, if the liquid is less than the pole, the empty pipe can be detected. Then the analog output, digital output and flow display become zero.

FLOW CALIBRATION POINT 1-4

Detailed, refer to Annex 2.

FLOW CALIBRATION NUMBER 1-4

Detailed, refer to Annex 2.



4.9.7 COMMUNICATION PARAMETER

COMMUNICATION ADDRESS

The address range is from 01 to 99 and address 0 is reserved, when communication.

COMMUNICATION SPEED

Communication baud rate range is 300, 600, 1200, 2400, 4800, 9600, 19200 and 38400.

COMMUNICATION TERMINAL RESISTANCE



Fig. communication terminal resistance switch Switch 1 or 2 means : ON means RS485 communication terminal resistance (120Ω) is connected. OFF means communication terminal resistance is not connected.

Note: communication terminal resistance is only used in long-way communication.

4.9.8 TIME PARAMETER

The parameters are used to set the clocks (year, month, date, hour, minute and second) used in power-down timing function and monthly gross function.

4.9.9 FACTORY CALIBRATION PARAMETER

FACTORY CALIBRATION COEFFICIENT

Factory calibration coefficient is the special coefficient of sensor-made-factory and the factory use this coefficient to unite MEFB electromagnetic flowmeter converters to make sure all the Meters can interchange by 0.1%.

CURRENT ZERO POINT AND FULL SCALE CALIBRATION

(1) Calibration preparation Power on meter and run it for 15 minutes to make the meter heat stable. Prepare level 0.1% ammeter or 250Ω resistance and level 0.1% voltmeter and connect to Factory calibration coefficient is the special coefficient of sensor-made-factory and the factory use this coefficient to unite MEFB electromagnetic flowmeter converters to make sure all the Meters can interchange by 0.1%.the meter as below:

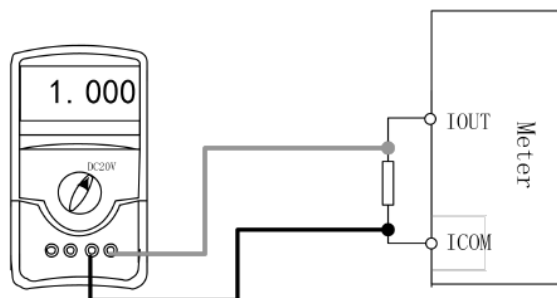



(2) Current zero calibration:

Set converter to parameter setting state and choose “current zero calibration” . Turn the standard signal source to “0” , adjust calibration parameter and make sure the display on ammeter is 4mA ($\pm 0.004\text{mA}$).

(3) Full scale current calibration

Choose “full scale current calibration” parameter and turn the standard signal source to full scale. Adjust convertor calibration parameter and make sure the display on ammeter is 20mA ($\pm 0.004\text{mA}$). When the current “0” and full scale is calibrated, the current function of convertor can meet the precision requirement. The linearity of the current output of convertor is within 0.1%.

GROSS ZERO CLEANING PASSWORD

The Password can be set in gross zero-point clearing function using level 2 password. Detailed,

4.9.10 INTEGRATING GROSS SETTING PARAMETER

INTEGRATING GROSS HIGH/LOW LEVEL

High/low level setting can change the gross flow and is applied to meter maintenance and change. Users can use level 2 password to get in and change the value of total flow. The upper limit is 999999999.

HEAT GROSS HIGH/LOW LEVEL

The setting method is the same with the setting of integrating gross high/low level.

Note: 8 bit calculator is applied when KWh or MWh is chosen and upper limit is 999999999. If the upper limit is beyond, 99999999 is displayed.

5 START UP

5.1 SWITCHING ON THE POWER

After connecting the MEF(B) 2100 Electromagnetic BTU meter converter and sensor to the pipe, follow these steps before proceeding:

- i. Verify that all electrical connections are properly secured and insulated.
- ii. Ensure that the power supply voltage and current rating match the BTU meter specifications.
- iii. Switch on the main power supply to the BTU meter system.
- iv. Confirm that the BTU meter displays a zero flow rate when there is no flow in the pipeline.
- v. Confirm that the flow readings are accurate and stable.
- vi. Ensure that all safety protocols are followed during the power-up process.
- vii. Be prepared to shut down the system immediately if any abnormal conditions are observed.

5.2 OPERATION KEY AND DISPLAY

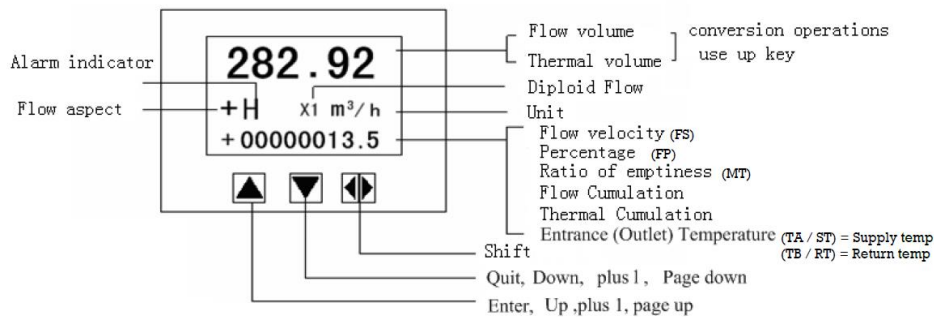

a) Keyboard function under automatic testing function

Up: The instantaneous heat (cold) and flow transfer; Heat displays as “H” and cold displays as “R” .

Down: Circular selection screen display content in lower line; Heat accumulating displays as “H” and cold accumulating displays as “C” .

Shift: Press “Shift” key once, comes into function choosing display;

b) Keyboard function under parameter setting

Up: Subtract 1 from the number at cursor area, turn into the Front Page;

Down: Plus 1 from the number at cursor area, turn into the After Page;

Press “Shift” key to move the cursor to “Up” key, press “Up” key to the submenu;

Press “Shift” key to move the cursor to “Down” key, press “Down” key return to the

father menu.

PARAMETER SETTING AND FUNCTIONAL KEY OPERATION

If the meter parameter setting or changing is applied, come into the parameter setting function thought testing function. Press “Shift” key once and go into the parameter setting function, move the cursor above “Up” key. Press “Up” key to go into “00000” status and then type in password. Move the cursor above “Up” key to

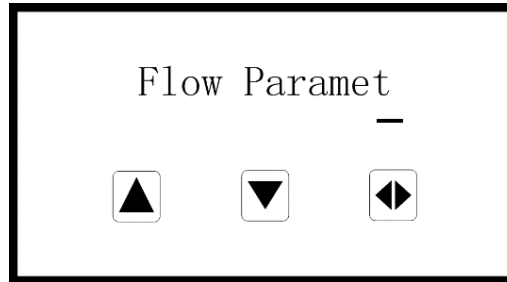

If need to change the main menu, press “Up” key. If need to change the sub menu parameter, move the cursor below the “Up” key. The figure is as below:

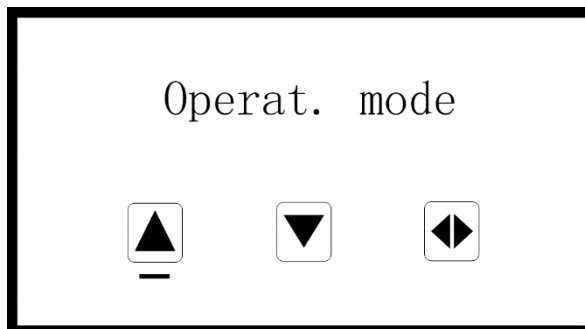

If entered the sub menu, move the cursor below the “Up” key to set the parameters. According to the security level, the password can be changed accordingly. The function can be chosen by pressing “Shift” key. There are 2 levels of passwords in meter design, level 1 user can set up passwords and level 2 password are fixed. The 2 passwords are of different security levels for different users.

REMOTE TYPE LCD DISPLAY



Note: During measurement, press the "compound key" and "Enter" buttons simultaneously to access the programming page. You will then be prompted to enter the password.. If you want to return to measurement display, push “Enter” for several seconds.



FUNCTION CHOOSING DISPLAY

Press “Shift” key to go into function choosing and then, press “Enter” key.
There are
five functions for choosing:

No.	Function	Remarks
1	Parameters Set	Parameter setting function is available by choosing this function
2	Clr total rec	Gross cleaning is available by choosing this function
3	Month total rec	32 months gross can be checked by choosing this function.
4	Power down rec	32 times power-down records can be checked by choosing this function.
5	Parameter changing record	Reserved

PARAMETER SETTING

Press “Shift” key once and go into the parameter setting function and then, type in password. Press “Shift” key and move the cursor to “Enter” key to do parameter 14 setting.

GROSS CLEANING

Press “Shift” key once and go into the parameter setting function and then, press “Up” key to “Gross Cleaning”, type in password. Press “Shift” key and move the cursor to “Enter” key, then press “Enter” key. When the password changes to

“00000”, the gross cleaning is done and the gross in meter becomes 0.

MONTHLY GROSS

The clock (powered by battery inside) in the meter can work more than five years continuously. If the Monthly Gross function or Power-down Timing function is applied, make sure that the clock in the meter can work as normal. Adjust the clock year, month, day, hour, minute and second; Make sure the battery inside works (change battery every five years)

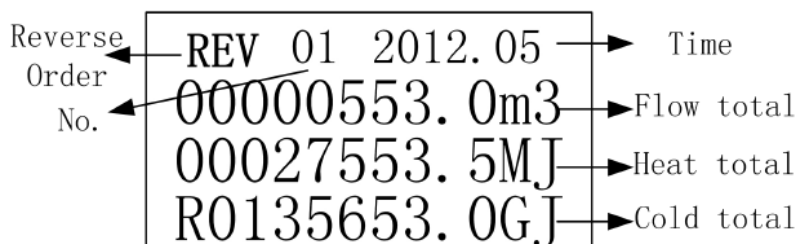



Monthly gross can record 32 months data and when the time is longer than 32 months, the new record will cover the first month record.

POWER-DOWN TIMING DISPLAY

32 times power-down records can be recorded and totally 9999 times of power-down records.

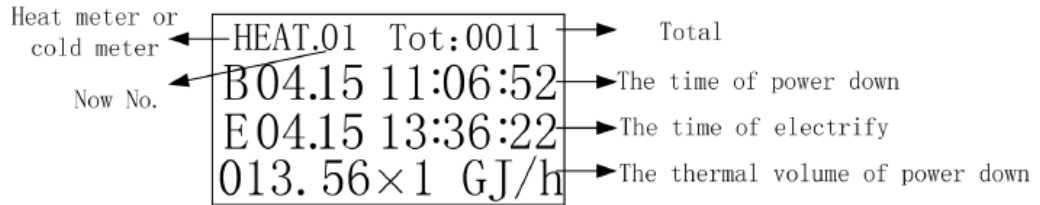

5.3 METER PERFORMANCE AND INDEX

- ♦ Low frequency square wave excitation, excitation frequency: 1/10 Power frequency, 1/12 Power frequency;
- ♦ Exciting Current: 125mA, 250 mA ;
- ♦ Empty pipe measuring with no additional pole, continuously measuring, alarm by fixed value ;
- ♦ Flow velocity measuring range: 0.1 to 15m/s, velocity resolution: 0.5mm/s ;
- ♦ 24V DC switching power supply.
- ♦ Network function: MODBUS(Standard), HART(Optional), GPRS(Optional), PROFIBUS(Optional);
- ♦ English for choosing(Other language is optional); Two Integrators insides to record flow and heat.

5.4 SENSORS CONNECTING TYPE

Split squared shells: squared shells hang on the wall, converters connected with sensor cable.

5.5 SENSOR REQUIREMENT

Sensitivity of sensor signal: under 1m/s, output 150μV~200μV;
For the meter, when using 125 mA current in excitation loop, 100Ω~110Ω resistance is applied. When using 250 mA current in excitation loop, 40Ω~60Ω resistance is applied.

5.6 DIGITAL FREQUENCY OUTPUT REQUENCY OUTPUT RANGE:

Frequency output range: 2000; Output Electrical Isolation: photoelectric isolation; isolation voltage > 1000V DC; Frequency output drive: FET output, Withstand voltage < 36VDC, Load current < 250mA

5.7 ANALOG CURRENT OUTPUT

Load resistance: 0-750Ω Basic error:
0.1%±10μA



5.8 DIGITAL COMMUNICATION INTERFACE AND COMMUNICATION PROTOCOL

RS485 Interface: Modbus protocol, RTU format, registers address refer to Annex 5,

Electrical isolation 1000V;

5.9 ELECTRIC ISOLATION

- Analog input and analog output isolation voltage should not be lower than 500V;
- Analog input and alarming power isolation voltage should not be lower than 500V;
- Analog input and AC power isolation voltage should not be lower than 500V;
- Analog output and AC power isolation voltage should not be lower than 500V;
- Analog output and earth isolation voltage should not be lower than 500V;
- Pulse output and AC power isolation voltage should not be lower than 500V;
- Pulse output and earth isolation voltage should not be lower than 500V;
- Alarming output and AC power isolation voltage should not be lower than 500V;
- Alarming output and earth isolation voltage should not be lower than 500V

5.10 FREQUENCY OUTPUT

- Frequency output range is 1-5000Hz and frequency output is usually used in control since it shows the flow percent, which is used to demarcate the meter.
- Frequency output=(Measure value / Meter range) * Full scale vale

5.11 DIGITAL OUTPUT WIRING

Digital output has two connectors: digital output connector and digital earth connector. The symbols are as below:

POUT - digital output connector; PCOM - digital earth connector;

POUT is open-collector output; the wiring is as follows:



5.12 DIGITAL LEVEL OUTPUT WIRING

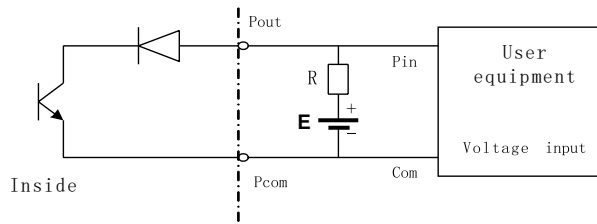

5.13 DIGITAL OUTPUT IS CONNECTED WITH OPTOCOUPLER (PLC ETC.)

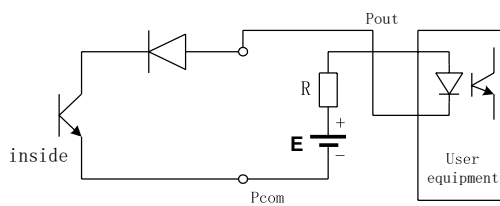

Generally, 10mA current is applied in optocoupler, $E/R=10\text{mA}$, $E=5\sim 24\text{V}$.

5.13.1 ANALOG OUTPUT IS CONNECTED WITH RELAY

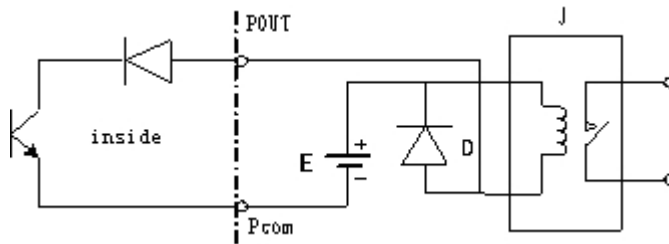

Generally, relay power supply is 12V or 24V.

D is free-wheeling diode and always exists inside middle relay. If the diode is not existed, the user should have one outside.

Digital output parameters are as follows:



POUT Parameter

Parameter	Test Condition	Minimum	Typical Value	Maximum	Unit
Working Voltage	IC=100mA	5	24	36	V
Working Current	Vol≤1.4V	0	300	350	mA
Working Frequency	IC=100mA Vcc=24V	0	5000	7500	Hz
High level	IC=100mA	Vcc	Vcc	Vcc	V
Low Level	IC=100mA	0.9	1.0	1.4	V

5.13.2 ANALOG OUTPUT

Analog output means 4-20mA signal system.

Analog current output is powered by 24V supply and can drive 750Ω resistance. Analog current output shows the flow percent:

Measure value

$$I_0 = \frac{\text{the scale of current} + \text{the zero point of current}}{\text{Full scale value}}$$

When 4-20mA signal system is applied, current zero is 4mA.

In order to enhance analog current resolution, appropriate flow range should be chosen.

Generally, all analog output parameters are calibrated within the factory and no need to recalibrate by users. If error occurs, the calibration can be done according to the introduction of zero-current full range parameter setting.

※Remark: When MEF 2100 heat meter and sensor are connected to the pipe, nomatter to use it or do the calibration, the following steps should be taken first:

Fix the pipe of front and rear of the sensor with copper wire to earth

Connect the sensor to earth

When doing the zero calibration, make sure the liquid in the pipe is in stillness

Make sure sensor electrode oxidation film is generated stable (electrode and liquid continuously contact for 48 hours)



6 ERROR DISPOSITIONS

6.1 NO DISPLAY

- ♦ Check whether the power is on
- ♦ Check whether the power fuse is in good condition
- ♦ Check whether the power voltage meets the requirement

6.2 EXCITATION MODE ALARMING (S)

- ♦ Check whether excitation wiring EX1 and EX2 is open circuit
- ♦ Check whether the total sensor excitation coil resistance is less than 150Ω
- ♦ If the items above are in normal, then the meter is malfunctioned

6.3 EMPTY PIPE ALARMING (T)

- ♦ Check whether the fluid is full of the sensor pipe
- ♦ Connect SIG1, SIG2 and SIGGND to short circuit, if the empty pipe alarming "T" disappeared, the meter is in normal condition; otherwise, the error may be caused by low fluid conductance, wrong setting of empty pipe threshold or range.
- ♦ Check whether the signal wiring is correct
- ♦ Check whether the sensor pole is in normal condition
- ♦ Make sure that flow is zero, and the displayed conductance ratio should be less than 100%
- ♦ If there is liquid in pipe, the resistance between SIG, SIG2 and SIGGND should be less than 50kΩ. (If the medium is water, it is better to use pointer multimeter to do the test and there is charge and discharge during the testing.)
- ♦ The DC voltage between DS1 and DS2 should be less than 1V, otherwise, it means the sensor pole is polluted and cleaning is needed.

6.4 FLOW INACCURATE

- ♦ Check whether the liquid is full of sensor pipe
- ♦ Check whether the signal line is in normal condition
- ♦ Check the sensor parameter and zero-point is set by sensor label or factory calibration



ANNEX 1: SELECTION OF EXCITING MODE (RE.)

MEF(B) affords two exciting frequency types, the small-caliber one should use 1/10 and large-caliber one should use 1/12. When using, please select 1/10 first, if the zero of velocity is too high, select the other one.

Note: Demarcate on which exciting type, working on it only.

When user's sensor connects to MEF(B) meter, the sensor exciting loop resistance is often not fit for the MEF(B) meter's requirement, at this time users can do like this:

(1) Small exciting loop resistance

If the exciting loop resistance is smaller than the meter's request, can series resistance to get the total value. The series resistance's power should be more than one time of fact, for example, series 10Ω on 250mA current, the power will be 3W.

(2) Large exciting loop resistance (change exciting current)

If the exciting loop resistance is larger than the sensor's request, can change the exciting current, for example, if exciting loop resistance is 70Ω, for 250mA this is larger, so can change the current to 187mA.

(3) Large exciting loop resistance (change loop connect)

If the exciting loop resistance is larger than the sensor's request, can change the connect of loop, for example, if exciting loop resistance is 200Ω, every exciting loop resistance is 100Ω, parallel connection the upper and lower loop is OK.

According the analysis, change the connect of exciting loop, measure from either head of exciting loop,

Total resistance = $(R_1 + RL_1)$ parallel connection $(R_2 + RL_2) \leq 120\Omega$;

(As the Fig. R₁, R₂----addition resistances; RL₁, RL₂ exciting resistances)

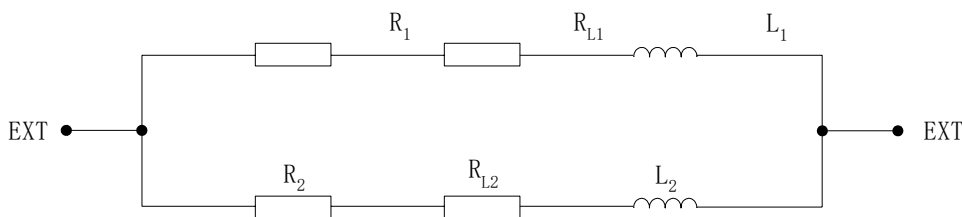

Total resistance = $(R_1 + RL_1)$ parallel connection $(R_2 + RL_2) \leq 120\Omega$;

(As the Fig. R₁, R₂----addition resistances; RL₁, RL₂ exciting resistances)

Sensor exciting current steady time so long (inductance is too large)

For this question, firstly changing exciting type, select 1/16 or 1/25 frequency. If cannot content, change connect of exciting loop.

Exciting current transition time $\tau = L / R$

L ---- Exciting loop inductance; R exciting loop resistance.

So decrease L and increase R both can decrease τ .

According the analysis, change the connect of exciting loop, measure from either head of exciting loop,

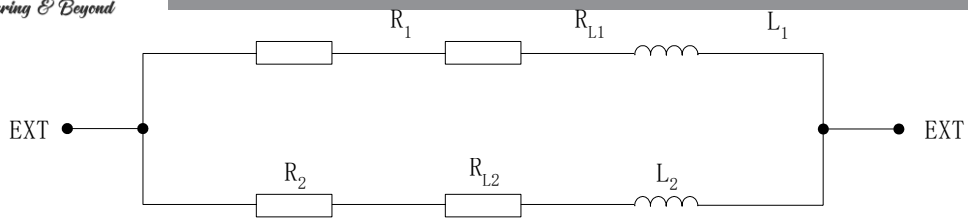

Total resistance = $(R_1 + R_{L1})$ parallel connection $(R_2 + R_{L2}) \leq 120\Omega$;
(As the Fig. R_1, R_2 ----addition resistances; R_{L1}, R_{L2} ----- exciting resistances)



ANNEX 2 FUNCTION OF NONLINEAR CALIBRATION

Nonlinear calibration function is applied when the flow is below 0.5m/s. The function has 4 calibration phases, which contain 4 calibration points and 4 calibration parameters. The calibration point should meet the following requirements: calibration point1> calibration point2> calibration point3> calibration point4>0
Calibration is done based on the sensor flow parameter curve. Sensor flow parameter should be obtained before doing the calibration, and then set the calibration parameter to do the calibration for different phase.

In the formats below, the Original Flow means the actual flow and the Calibration Flow means flow after calibration:

If Calibration point 1 > Original Flow \geq Calibration point 2; Calibration Flow = Calibration Parameter 1 \times Original Flow ;

If Calibration point 2 > Original Flow \geq Calibration point 3; Calibration Flow = Calibration Parameter 2 \times Original Flow ;

If Calibration point 3 > Original Flow \geq Calibration point 4; Calibration Flow = Calibration Parameter 3 \times Original Flow ;

If Calibration point 4 > Original Flow \geq 0;

Calibration Flow = Calibration Parameter 4 \times Original Flow ; Note: When setting the calibration point, make sure

calibration point1> calibration point2> calibration point3> calibration point4>0

The middle of calibration parameter is 1.0000, if the parameter is larger than 1, the calibration flow will be higher than the original flow; otherwise, the calibration flow will be lower than the original flow



ANNEX 3 METER MENU

Parameter No.	Meaning	Range	Range
1	Flow Paramet		
1	Operat. mode	Heat meter modeCold meter mode Cold—Heat mode	Choose
2	Snsr Size	10~2000	Choose
3	Heat Unit	GJ/h, MJ/h, KWh/h, MWh/h	Choose
4	Cold Unit	GJ/h, MJ/h, KWh/h, MWh/h	Choose
5	Flow Rspns	1~60S	Choose
6	Flow Direct	FORWARD, REVERSE	Choose
7	Flow Zero	0~±9999	Number set
8	Flow Cutoff	Based on flow setting	Number set
9	Tempe.Cutoff	0~199.9	Number set
10	Total Unit	0.001m ³ ~1m ³	Choose
11	HeatTotUnit	MJ, GJ, KWh, MWh	Choose
12	ColdTotUnit	MJ, GJ, KWh, MWh	Choose
2	Output Param		
2.1	Current Mode	Flow output Heat output Cold output Heat Cold outputStatus output Flow direction	Choose
2.2	Flow Range	0~59999	Number set
2.3	Heat Range	0~59999	Number set
2.4	Cold Range	0~59999	Number set
2.5	Data Output	Flow FrequencyFlow Pulse Lt Flow Pulse m3 Heat Pulse MJ Heat Pulse GJ Heat Pulse KWhHeat Pulse MWhCold Pulse MJ Cold Pulse GJ Cold Pulse KWhCold Pulse MWh Cold Heat P MJ Cold Heat P GJCold Heat P KWh	Choose



		Cold Heat P MWhWorkStatus Mark Flow direction	
2.6	FrequencyMax	0~59999	Number set
2.7	Pulse Factor	0.001~59.999	Number set
2.8	Pulse Width	0.3ms~499.9ms	Number set
3	Sensor Param		
3.1	Sensor Fact	0.0000~5.9999	Number set
3.2	Field Type	Type1/Type2	Choose
3.3	Snsr Code1	0~99999	User set
3.4	Snsr Code2	0~99999	User set
3.5	Sensor Post.	Flow Inlet Flow export	Choose
4	Temperature		
4.1	Heat Start T	0~199.9	Number set
4.2	Cold Start T	0~199.9	Number set
4.3	Pres. Range	0.6MP/6MP	Choose
4.4	TempA Zero	0~59999	Number set
4.5	TempA Range	0~5.999	Number set
4.6	TempB Zero	0~59999	Number set
4.7	TempB Range	0~5.999	Number set
5	Alarm Param		
5.1	Mtsnsr Ena	ENABLE/DISABLE	Choose
5.2	MtsnsrTrip	59999	Number set
5.3	Sys Alm Ena	ENABLE/DISABLE	Choose
6	Linearizati		
6.1	Line Crc Ena	ENABLE/DISABLE	Choose
6.2	Lineary CRC1	Based on flow setting	User set
6.3	Lineary Fact 1	0.0000~9999	User set
6.4	Lineary CRC2	Based on flow setting	User set
6.5	Lineary Fact 2	0.0000~9999	User set
6.6	Lineary CRC3	Based on flow setting	User set
6.7	Lineary Fact 3	0.0000~9999	User set
6.8	Lineary CRC4	Based on flow setting	User set
6.9	Lineary Fact 4	0.0000~9999	User set
7	Communicati		
7.1	Comm Addres	0~99	Number set
7.2	Baud Rate	300~38400	Choose
8	Date paramet		
8.1	YEAR	0~99	Number set
8.2	MONTH	0~99	Number set
8.3	DAY	0~99	Number set



8.4	HOUR	0~99	Number set
8.5	MINUTE	0~99	Number set
8.6	SECOND	0~99	Number set
9	Factory Adj		
9.1	Meter Fact	0.0000~5.9999	Number set
9.2	AnalogZero	0.0000~9999	Number set
9.3	Anlg Range	0.0000~3.9999	Number set
9.4	Clr Sum Key	0~99999	Modify available
9.5	MeterCode1	0~99999	Factor set
9.6	MeterCode2	0~99999	Factor set
9.7	Password 1	0~59999	Modify available
9.8	Language	English	Choose
10	Test paramet		
10.1	Heat Test	ENABLE/DISABLE	Choose
10.2	TempA value	0~199.9	Number set
10.3	TempB value	0~199.9	Number set
10.4	Speed value	0~19.999	Number set
11	Total parame		
11.1	TotalWordLo	0~99999	Modify available
11.2	TotalWordHi	0~9999	Modify available
11.3	HeatTotalLo	0~99999	Modify available
11.4	HeatTotalHi	0~9999	Modify available
11.5	ColdTotalLo	0~99999	Modify available
11.6	ColdTotalHi	0~9999	Modify available

Meter parameters determine the operational status, calculation method, output method and status. Proper selection and set the meter parameters can make sure the meter works in the best state, and has higher measurement accuracy and measurement precision of output display.

Meter parameters setting function has 2 level password. Level 1 password is user password and level 2 password is factory password. The user can use the level 2 password to set the level 1 password.

If the user needs to change the meter parameter, different level password is needed.

Level 1 password (factory set 00521): read only

Level 2 password (set 19818): user can change the parameter



ANNEX 4 HEAT MEASUREMENT INSTRUCTION MANUAL

Temperature calibration method:

Pt1000 thermal resistance three-wire bridge connection method is applied in temperature measurement, wiring is as below:

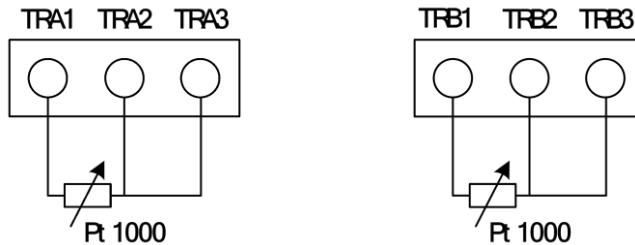

Current zero-point calibration and range calibration should be applied in thermal resistance measurement circuit. The convertor has be calibrated in the factory and if calibration is still needed, follow the below steps:

A, use resistance box (connect according to three-wire bridge)

Step 1: Choose 1000Ω resistance and adjust zero-point value (generally, 32768) in the entrance (outlet) temperature zero-point parameter until the upper line of the LCD shows “0”.

Step 2: Choose 1535.8Ωresistance and adjust zero-point value (generally, 1.2) in the entrance (outlet) temperature zero-point parameter until the upper line of the LCD shows “1400”.

B, use blackbody furnace (connect according to three-wire bridge)

Step 1: Put thermal resistance ice water immersion, adjust zero-point value (generally, 32768) in the entrance (outlet) temperature zero-point parameter until the upper line of the LCD shows “±0”.

Step 2: Choose temperature 140 °C of blackbody furnace, put the thermal resistance into blackbody furnace, adjust zero-point value in the entrance (outlet) temperature zero-point parameter until the upper line of the LCD shows “1400”.

2 Heat calculation method

The heat calculation is done according to CJ128—2007. Heat calculation:

When the water flows through the installed integrated heat meter or combined meter, the water signal is obtained based on the water flow and temperature from the sensor. The calculation is done based on the water signal and flow time to show the heat released or absorbed.

The format is:



$$Q = \int_{\tau_0}^{\tau_1} q_m \times \Delta h \times d \tau \quad \int_{\tau_0}^{\tau_1} \rho \times q_v \times \Delta h \times d \tau$$

Q - Heat released or absorbed (J); q_m – Water flow (kg/h);

q_v - Water volume flow (m³/h); ρ – Water density (kg/m³);

Δh - Enthalpy difference between entrance water temperature and outlet water temperature (J/kg);

T – Time (h).

In the format, the density and enthalpy is in compliance with the Annex A requirement of CJ128-2007. If the temperature is not integer, the calibration is needed.

Remark: The measurement of the quantity of heat is calculated by using hot melting value of entrance and exit multiplying flow. So the calculated value relates to increment of one second of accumulative flow. That is to say, every time accumulative flow generates one increment, the quantity of heat should be calculated. So unit of accumulative flow should not be adjusted too much, avoiding that it takes long time to generate one accumulative flow increment. Accumulative flow is represented by 9 bits decimal numbers (999999999). Flow unit is 0.001 m³, 0.01m³, 0.1 m³, 1 m³. The choice of flow unit should meet the demand that it won't overflow in 2-3 years.



ANNEX 5 MODBUS REGISTER ADDRESS DEFINITIONS

Protocol Addresses (Decimal)	Protocol Addresses (HEX)	Data Format	Register Definition
4112	0x1010	Float Inverse	Instantaneous flow floating-point(M3/h)
4114	0x1012	Float Inverse	Instantaneous flow velocity floating-point
4116	0x1014	Float Inverse	Reserved
4118	0x1016	Float Inverse	Flow conductance ratiofloating-point
4120	0x1018	Long Inverse	Gross integer part
4122	0x101A	Float Inverse	Gross decimal value
4124	0x101C	Unsigned short	Instant cold unit 0 : MJ/h; 1 : GJ/h 2 : KWh/h; 3 MWh/h
4125	0x101D	Unsigned short	Cold gross unit 0 : MJ ; 1 : GJ 2 : KWh; 3 MWh
4128	0x1020	Unsigned short	Instantaneous heat unit 0 : MJ/h; 1 : GJ/h 2 : KWh/h; 3 MWh/h
4129	0x1021	Unsigned short	Flow gross unit(m3)
4130	0x1022	Unsigned short	Pressure range 0: 0.6MPa 1: 1.6MPa
4131	0x1023	Unsigned short	Gross heat unit 0: MJ 1: GJ; 2: KWh 3: MWh
4132	0x1024	Unsigned short	Empty pipe alarming 0: Normal 1: Alarming
4133	0x1025	Unsigned short	System alarming 0: Normal 1: Alarming
4134	0x1026	Float Inverse	Instantaneous heat flow
4136	0x1028	Long Inverse	Heat gross
4138	0x102A	Float Inverse	Heat gross decimal value
4140	0x102C	Unsigned short	Entrance temperature(°C)
4141	0x102D	Unsigned short	Outlet temperature(°C)
4142	0x102E	Long Inverse	Cold gross accumulating value
4144	0x1030	Float Inverse	Cold gross accumulating smallamount
4146	0x1032	Float Inverse	Instant cold value



MIAL[®]
INSTRUMENTS PVT.LTD.
Measuring & Beyond

USA OFFICE ADDRESS

MIAL INSTRUMENTS PVT. LTD.
Downtown Republic Center
325 N. St.Paul Street, Suite 3100
Dallas 75201, Texas, USA

FACTORY ADDRESS

MIAL INSTRUMENTS PVT. LTD.
856/ 6 GIDC
Makarpura, Vadodara 390010, Gujarat, India
+91-9913449547/9913449548

Email : info@mialinstruments.com
www.mialinstruments.com



**MIAL
INSTRUMENTS**
Measuring & Beyond

856/6, GIDC MAKARPURA, VADODARA - 390010
Phone : +91-9913449547 / +91-9913449548
E-MAIL : info@mialinstruments.com
WWW : www.mialinstruments.com