

| INSTALLATION & OPERATION MANUAL

MEF(B)2100 Inline Electromagnetic BTU Meter



MIAL[®]
INSTRUMENTS PVT. LTD.
Measuring & Beyond

www.mialinstruments.com

MEF(B) 2100

Inline Electromagnetic BTU Meter

Preface

- Thank you for purchasing our product.
- This manual is about the various functions of the product, wiring methods, setting methods, operating methods, troubleshooting methods, etc.
- Please read this manual carefully before operation, use this product correctly to avoid unnecessary losses due to incorrect operation.
- After you finish reading, please keep it in a place where it can be easily accessed at any time for reference during operation.



NOTE!

Modification of this manual's contents will not be notified as a result of some factors, such as function upgrading. We try our best to guarantee that the manual content is accurate, if you find something wrong or incorrect, please contact us. The content of this manual is strictly prohibited from reprinting or copying.

About this manual

- Please submit this manual to the operator for reading.
- Please read the operation manual carefully before installing the instrument. On the precondition of full understanding.
- This manual only describes the functions of the product. The MIAL Instruments pvt.ltd. does not guarantee that the product will be suitable for a particular application.

Warnings and symbols used



HAZARD!

If not taken with appropriate precautions, will result in serious personal injury, product damage or major property damage.



WARNING!

Pay special attention to the important information linked to product or particular part in the operation Manual



CAUTION!

Disregarding these instructions can result in damage to the device or other ancillary products



INFORMATION!

These instructions contain important information for the handling of the device.



1. INTRODUCTION

1.1 PURPOSE OF THE MANUAL

Overview:

Welcome to the user manual for the Mial MEF(B) 2100 - Electromagnetic BTU meter. This comprehensive guide is designed to assist operators, maintenance personnel, and system integrators in understanding, installing, operating, and maintaining the Mial MEF(B) 2100 - Electromagnetic BTU meter effectively.

Objectives:

Clarification of Functionality: This manual aims to provide a clear understanding of the principles and functionality of the Mial MEF(B) 2100 - Electromagnetic BTU meter. Users will gain insights into its design, components, and how it precisely measures fluid flow.

Guidance for Installation:

Step-by-step instructions and considerations for proper installation are provided to ensure optimal performance. Safety precautions are emphasized to create a secure working environment.

Training and Familiarization:

Users will be guided through the features, controls, and indicators of the BTU meter, facilitating efficient operation. This section aims to serve as a valuable training resource for users at various experience levels.

Maintenance and Troubleshooting Assistance:

Learn about routine maintenance procedures and effective troubleshooting techniques. This manual empowers users to address common issues and perform regular maintenance to enhance the longevity of the Mial MEF(B) 2100 - Electromagnetic BTU meter.

Intended Audience:

This manual is intended for operators, maintenance personnel, and system integrators involved in the installation, operation, and maintenance of the Mial MEF(B) 2100 - Electromagnetic BTU meter. It is suitable for both novice users seeking basic guidance and experienced professionals looking for specific details.

Important Notes:

Please read through the manual carefully, adhering to safety guidelines and following instructions precisely. If any uncertainties arise during the installation, operation, or maintenance processes, seek assistance from qualified personnel or our customer service / support team.

Reference to Other Documentation:

Refer to the accompanying technical specifications document for in-depth details about the Mial MEF(B) 2100 - Electromagnetic BTU meter. Additional resources can be found on our website.



Intended use



CAUTION!

Responsibility for the use of the measuring devices with regard to suitability, intended use and corrosion resistance of the used materials against the measured fluid lies solely with the operator.



INFORMATION!

The manufacturer is not liable for any damage resulting from improper use or use for other than the intended purpose

Certification



The manufacturer certifies successful testing of the product by applying the CE marking



The manufacturer certifies successful testing of the product by applying the ISO marking

1.2 OPERATING PRINCIPLE

1.2.1 OPERATING PRINCIPLE OF BTU METER

Heat meter operating principle: Hot (cold) water supplied by a heat source flows into a heat exchange system at a high (low) temperature (a radiator, heat exchanger, or complex system consisting of them), Outflow at low (high) temperature, in which heat is released or absorbed to the user through heat exchange (note: this process includes energy exchange between heating system and cooling system). When water flow through the heat exchange system, according to the flow sensor of flow and matching the temperature of the sensor is given for the return water temperature, and flow through time, through the calculation of the calculator and display the system heat release or absorption.

$$Q = [q_m \times \tau \times \Delta h \times \rho] = [q_v \times \Delta h \times \rho \times \tau]$$

Q : Heat released or absorbed by the system, JorkWh;

q_m : Mass flow of water through a heat meter, kg/h ;

q_v : Volume flow of water through the heat meter, m³/h ;

ρ : The density of water flowing through the heat meter, kg/ m³ ;

Δh : The difference in enthalpy between inlet and outlet temperatures of the heat exchange system, J/kg ;

τ : time, h.

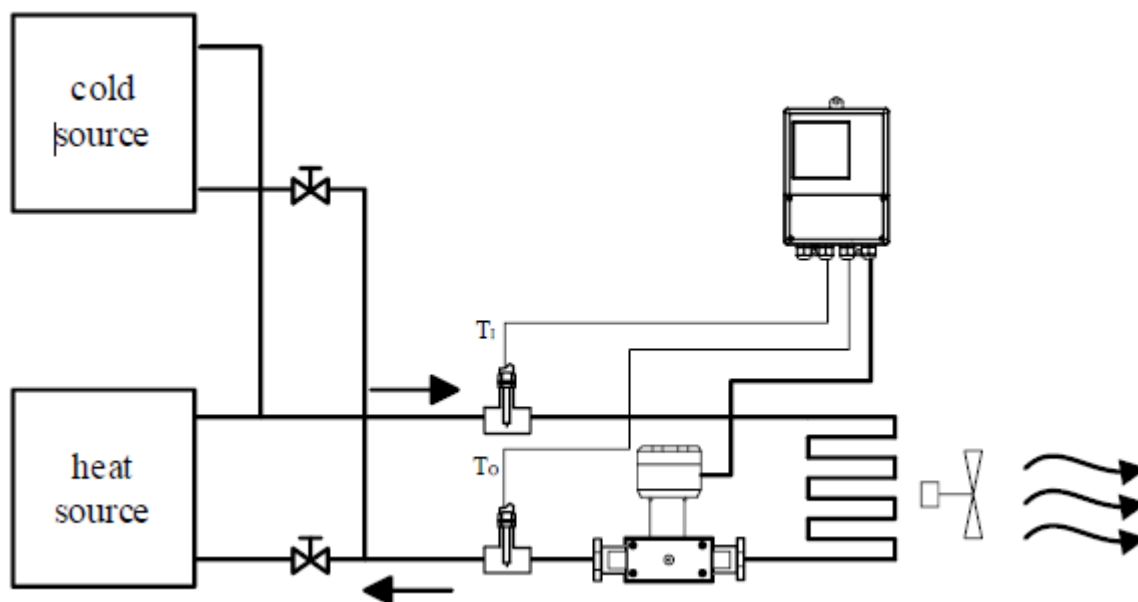

1.2.2 PRINCIPLE OF ELECTROMAGNETIC FLOWMETER MEASUREMENT

The working principle of electromagnetic flowmeter is based on Faraday's electromagnetic induction law. In the figure, the two electromagnetic coils at the top and bottom generate constant or alternating magnetic fields. When the conduction medium flows through the electromagnetic flux, the induction electromotive force can be detected between the left and right electrodes on the wall of the flowmeter. The magnitude of this induction electromotive force is proportional to the velocity of the conducting medium, the magnetic induction intensity of the magnetic field and the conductor width (the inner diameter of the flowmeter measuring tube). The equation of induced electromotive force is:

$$E = K \times B \times V \times D$$

Among them:

E—induced electromotive force

K—instrument factor

B—Magnetic induction intensity

V—average flow rate in the pipe section

D—the inner diameter of the pipe

Measuring flow rate, fluid flows through the magnetic field perpendicular to the flow direction, fluid flow induction conductivity an induction electric potential is proportional to the average flow velocity, so the measured conductivity is higher than the minimum of the electric conductivity of liquid flow - 5 us/cm (electromagnetic flowmeter can measure conductivity greater than 5 us/cm theoretically conductive medium, but should guarantee the electromagnetic flowmeter in practical measurement used in the electrical conductivity measured medium in 30 us/cm or above (greater than the theoretical value for one to two orders of magnitude) environment, and must be based on online measurement of electrical conductivity value). The induced voltage signal through two electrodes detection, and through the cable sent to converter, after a series of analog and digital signal processing, cumulative flow and transient flow display screen in converter.

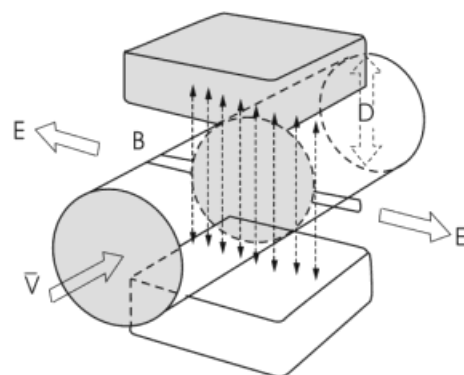



1.2.3 USE ENVIRONMENT DESCRIPTION

Electromagnetic flowmeter applies only to measure the instantaneous flow rate of an electrically conductive liquid or liquid-solid two-phase flow, and has a flow accumulation function. Typically, the meter factory parameters will vary depending on the requirements of the order set in advance, the user does not need to set parameters before use, but requires the user to the nameplate on the pre-use check whether the parameters have been set up in advance, and with the actual working conditions do check.

Theoretically medium conductivity of not less than $5\mu\text{S} / \text{cm}$ can use ordinary type electromagnetic flowmeter cm, but the fact that ordinary electromagnetic flowmeter can measure the electrical conductivity higher than the theoretical value should be one to two orders of magnitude, at least more than $30\mu\text{S} / \text{cm}$. Meanwhile conductivity measurement must be online measured conductivity prevail, there will be off-line measurement of air carbon dioxide, nitrogen dioxide dissolved into the media resulting in higher conductivity.



1.3 MEF(B) 2100 SPECIFICATIONS*

Operation and performance

Flow measurement Technology

The flow measurement technology of electromagnetic flow/BTU meters is based on Faraday's law of electromagnetic induction, where the induced voltage across electrodes is proportional to the fluid velocity, allowing for accurate flow measurement.

Fluid types

Electrically conductive fluids such as water

(Hot Water, Chilled Water, Condensate Water, Domestic Water, Waste Water etc.)

Conductivity

>20us/cm

Pipe sizes

15 MM –2000 MM

Pipe materials

Metallic and Non Metallic pipes.

Flow accuracy

Standard :±0.5%

Optional: ±0.2%

Achievable with process calibration

Repeatability

Flow:±0.17%

BTU: ±0.27%

Linearity

Standard: ±0.5%

Optional: ±0.2%

Measuring range

Max 0–40 ft/s

Measurement parameters

Btu meter – Instantaneous energy rate, totalized energy, Instantaneous flow rate, totalized flow, supply temperature and return temperature

Certification

Factory calibration certification, CE, ISO

Electronics

Enclosures

Aluminium

Use weather proof enclosure while installing the transmitter outside

Enclosure IP rating

IP 65

EEPROM Memory

Yes

Power supply

24 VDC/2A

Use 2–amp SMPS when employing AC power

Ambient temperature

32°F to 140°F (0°C to 60°C)

Relative Humidity

5– 95% RH

Standard Analog outputs

Flow meter– 4–20 mA

Output programmed for current flow rate. 500 Ω maximum load,

Btu meter– 4–20 mA

output programmed for current flow rate or current energy rate.500 Ω maximum load

Pulse Outputs

Flow Meter– Pulse

Programmed for Flow Consumption , Contact pulse Duration –0.1~300 ms

Btu meter – Pulse

Programmed for Enery Consumption or Flow consumption , Contact pulse Duration –0.1~300 ms

Network Connection

Modbus RTU RS485

Cable

10M

Flow tube specification

Coil material

Pure Copper

99% copper (Cu) content, excellent electrical conductivity, corrosion resistance

Process connections

Standard: ANSI 150 flanges

Optional: ANSI 300 flanges

Operating temperature

14°F to 248°F (–10°C to 120°C)

Nominal Pressure

Standard: 1.6 Mpa

Optional: 2.5 Mpa, 4.0 Mpa, 5Mpa

Flow Tube

SS 304

Electrode Material

Standard: SS 316L

Optional: Hastelloy, Titanium, Tantalum,



Liner

Standard: PTFE Optional:
Ebonite, Polyebonite,

Flange

Standard: Carbon Steel
Optional: Stainles steel

Mountings

Flanged flow tube

IP rating

Flow tube : IP68

Tramsmmitter : IP 65

Energy measurement

Temperature sensor

PT1000

22°F to 392°F (-30°C-200°C)

Wetted insertion thermowell

Cable

10 M

**Specifications are subject to change without prior notice.*



1.4 SUPPLEMENTARY ACCESSORIES THAT COULD BE NEEDED

1.4.1 GROUNDING RINGS

Grounding rings may be needed when meters are installed in non-metallic pipes or lined pipes. Placing these rings before and after the meter helps to reduce electrical interference, allowing the meter to function accurately. Mial Instruments provides these grounding rings as an optional accessories.

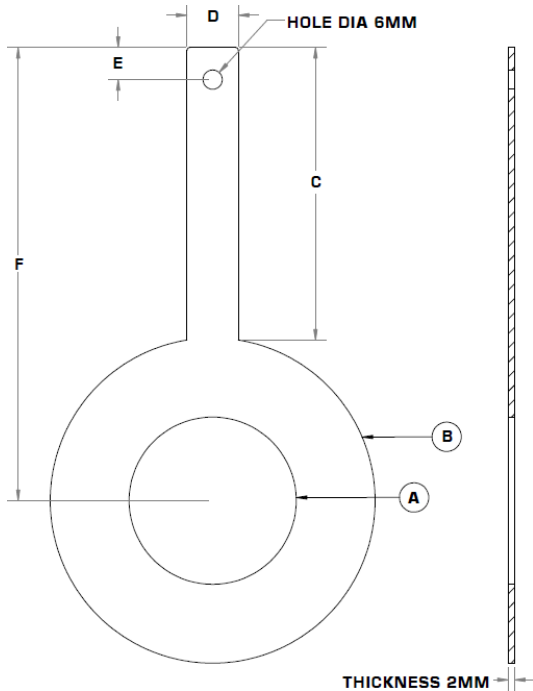

GROUNDING RING SIZES						
ALL DIMENSIONS ARE FOR FLANGE 150#						
SIZE (MM)	A (ID)	B (OD)	C	D	E	F
15	18	40	50	16	10	70
20	23	42	60	16	10	81
25	26	62	60	16	10	91
32	32	63	60	16	10	91.5
40	40	80	60	16	10	100
50	52	101	60	16	10	110.5
65	63	104	70	20	10	122
80	80	130	70	20	10	135
100	104	158	75	20	10	154
125	130	187	75	20	10	168.5
150	158	217	75	20	10	183.5
200	206	267	75	20	10	208.5
250	260	328	75	20	10	239
300	310	375	85	20	10	272.5

ALL DIMENSIONS IN MM



INFORMATION!

Mandatory to loop between the grounding rings by using a proper wire and connect the end of the wire to a ground source in the DDC panel. (please add this sentence in the above paragraph)





2. DEVICE DESCRIPTION

2.1 SCOPE OF DELIVERY

-  **INFORMATION!**
Do a check of the packing list to make sure that you have all the elements given in the order

-  **INFORMATION!**
Inspect the packaging carefully for damages or signs of rough handling. Report damage to the carrier and to the local office of the manufacturer.

-  **INFORMATION!**
The field device will arrive in one standard cartons. The standard carton contains one small corrugated box containing Transmitter Unit,. Also, the standard carton box contains Flow Tube,Supply Temperature Sensor, Return Temperature Sensor,Product documentation, Test Certificates, Allen key & bolts sets

-  **INFORMATION**
The MEF(B) 2100 transmitters and sensor bodies are components of a uniquely calibrated system and must be installed together as per the serial number. Mixing components from other systems will result in significant calibration errors.The transmitter serial number can be found on the sticker on the side of the electronics enclosure, and the sensor serial number is located on the sticker on the sensor body.

-  **INFORMATION!**
Grounding Ring will be provided only if the pipe material is Non-Metallic & will be charged additional

-  **INFORMATION!**
Mandatory to loop between the grounding rings by using a proper wire and connect the end of the wire to a ground source in the DDC panel.

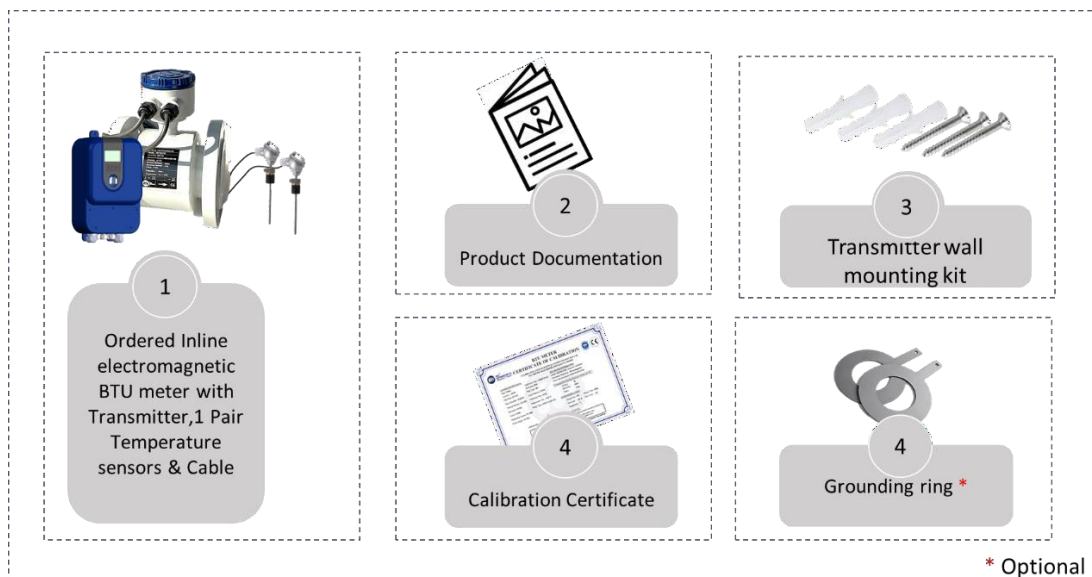

2.2 NAMEPLATES



INFORMATION!

Look at the device nameplate to ensure that the device is delivered according to your order. Check for the correct supply voltage printed on the nameplate

NAMEPLATE FOR THE TRANSMITTER

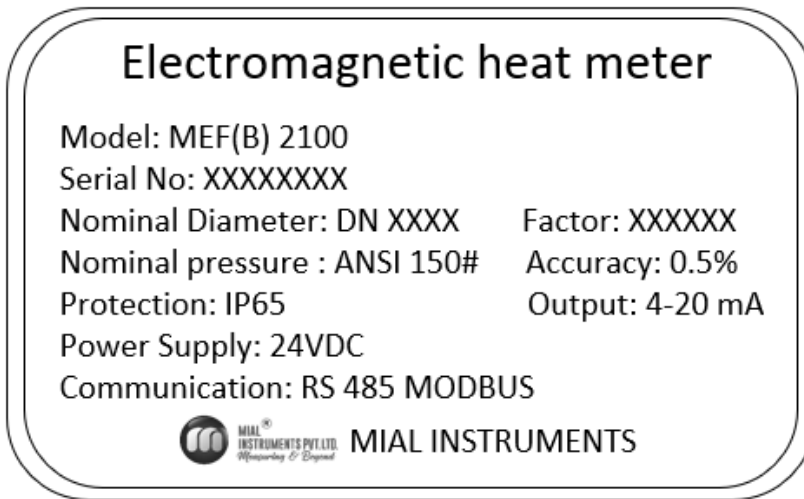

NAMEPLATE FOR THE FLOW TUBE

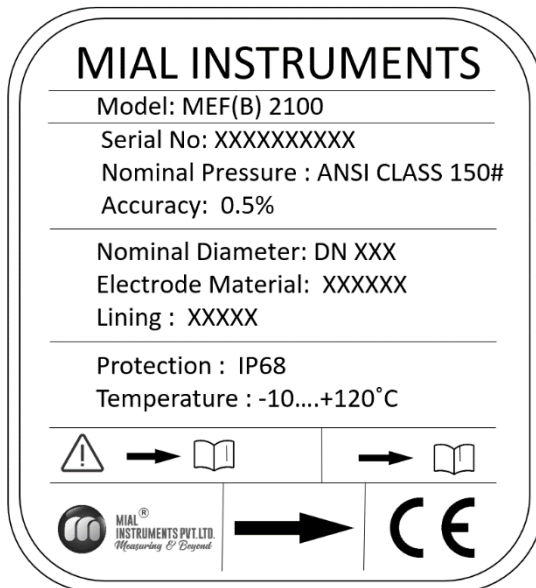

3. INSTALLATION

3.1 SITE SELECTION

When selecting a site for a BTU meter installation, prioritize accessibility for installation and maintenance. Consider environmental factors like temperature and humidity as per guidelines. Ensure the flow profile is stable and the pipe is in good condition. Safety and ease of access for personnel should also be taken into account to optimize meter performance and longevity.

3.1.1 BASIC RECOMMENDATIONS

In general guidelines, it's recommended to find a location where the pipe has the longest straight segment with a clear run. This ensures smooth laminar flow of the fluid through the meter, which is crucial for accurate measurement. A longer clear run of pipe minimizes disturbances and turbulence that could affect the meter's performance. This approach helps optimize the meter's accuracy and reliability by providing a stable flow profile for measurement.

3.1.2 FLOW DIRECTION

The Mial MEF(B) 2100 BTU meter should be installed ensuring the arrow indicated on the meter points in the direction of flow. When correctly installed, as illustrated, the arrowhead should align with the flow direction. The transmitter display will indicate positive values corresponding to the flow direction indicated by the arrow. If the fluid flows in the opposite direction to the arrow, the display will show negative readings reflecting the reverse flow direction.

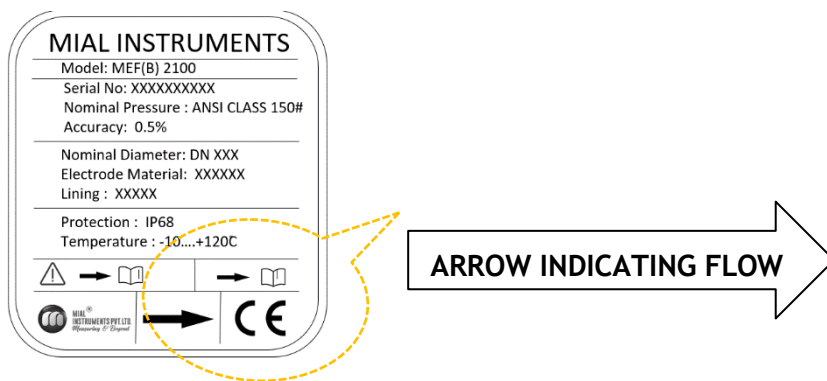

3.1.3 INSTALLATION OF REMOTE MOUNT TRANSMITTER

Installing a remote mount transmitter involves placing the unit at a distance where the display is easily visible to the user. It should be positioned away from equipment that may generate electrical interference. The standard cable length from the flow tube to the transmitter becomes 10 meters and it can't be cut or extendable at the site. For the outdoor installation mandatory to provide a non-metallic FRP/GRP enclosure



3.1.4 STRAIGHT LENGTH REQUIREMENT

The diagrams below demonstrate the minimum straight length necessary to ensure accurate readings from the BTU meter. Having additional straight length beyond this minimum requirement offers additional advantages, such as enhanced measurement precision and reduced potential for turbulence or flow disturbances that could affect meter performance. Therefore, maximizing the straight length of the pipe where the BTU meter is installed can contribute to optimizing the overall effectiveness and reliability of the measurement process.

SLOP & VERTICAL LINES

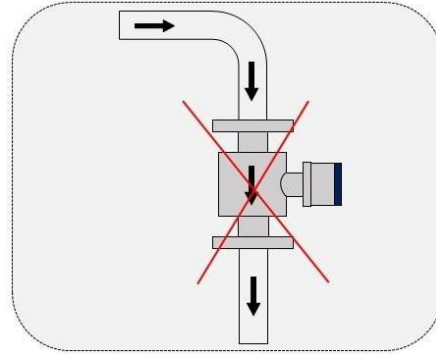
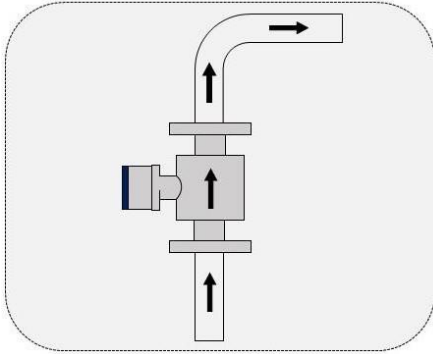

Install at the rising direction

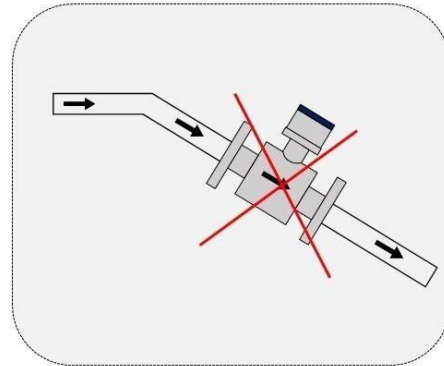
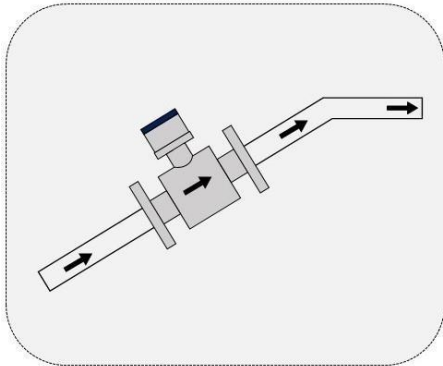

OPEN FEED OR DISCHARGE

Install at the rising direction

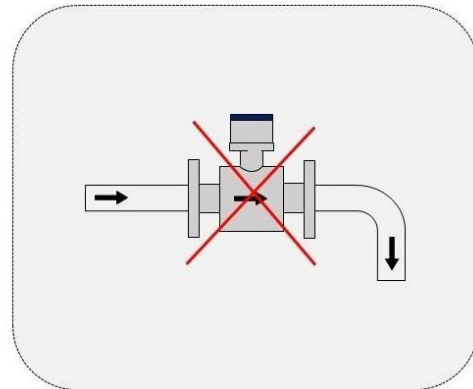
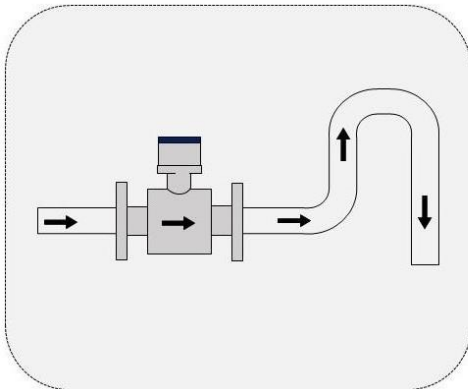

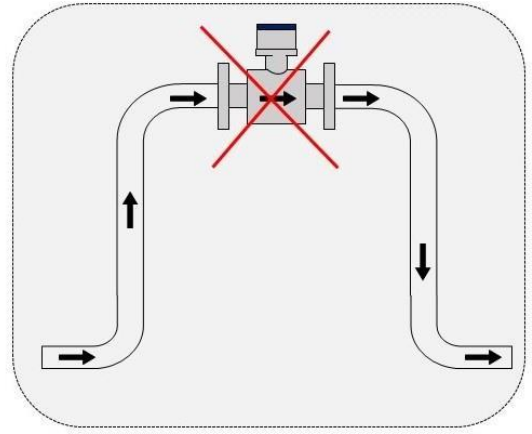
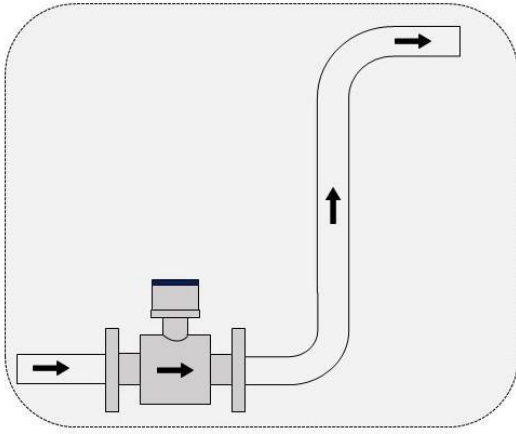

Install at the lowest point when used in open drain pipe

CONTROL VALVE

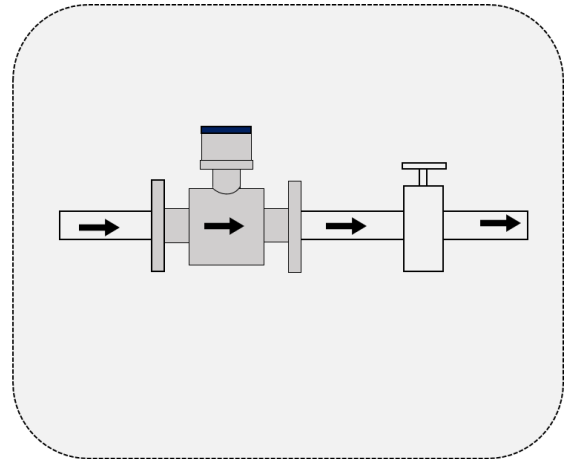
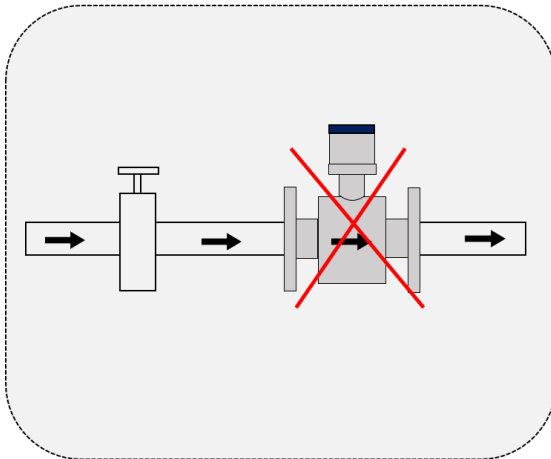

Don't install it at the exit of the valve, install it at the entrance of the valve

POSITION OF PUMP

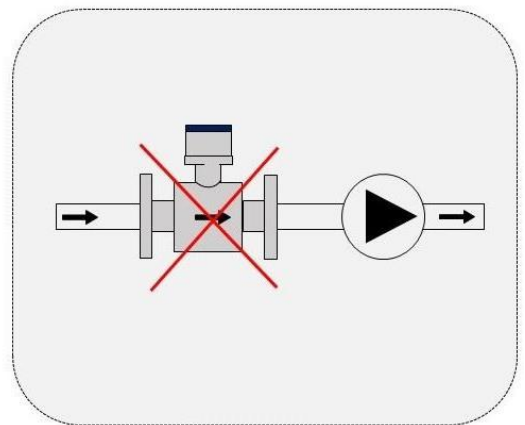
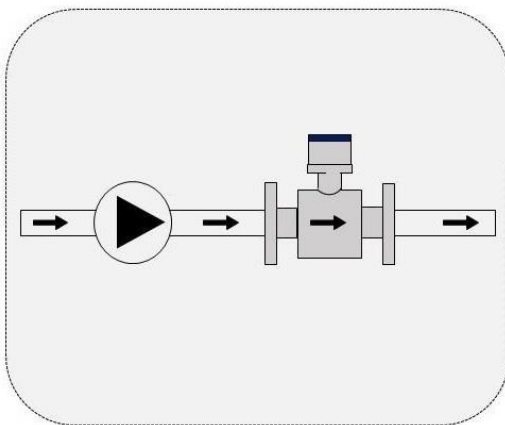

Don't install it at the entrance of the pump, install it at the exit of the pump



DOWN GOING PIPELINE OVER 5 M /16 FT LENGTH

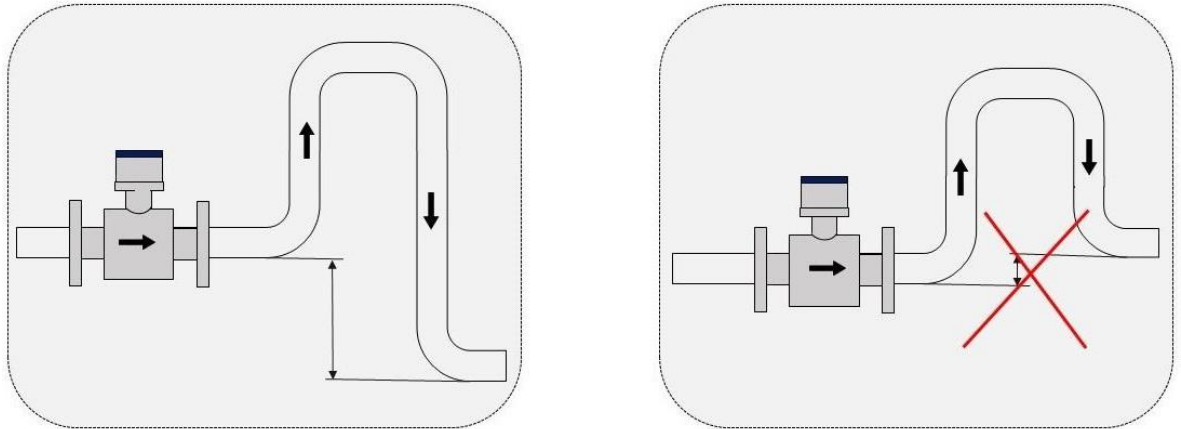

The downstream of BTU meter when the drop is more than 5 m

3.2 MECHANICAL INSTALLATION



IMPORTANT NOTE!

MEF(B) 2100 transmitters and sensor bodies are two parts of one uniquely calibrated system and must be installed together as per the serial Number . Mixing components from other systems will result in significant calibration errors.

3.2.1 STANDARD TRANSMITTER DIMENSIONS

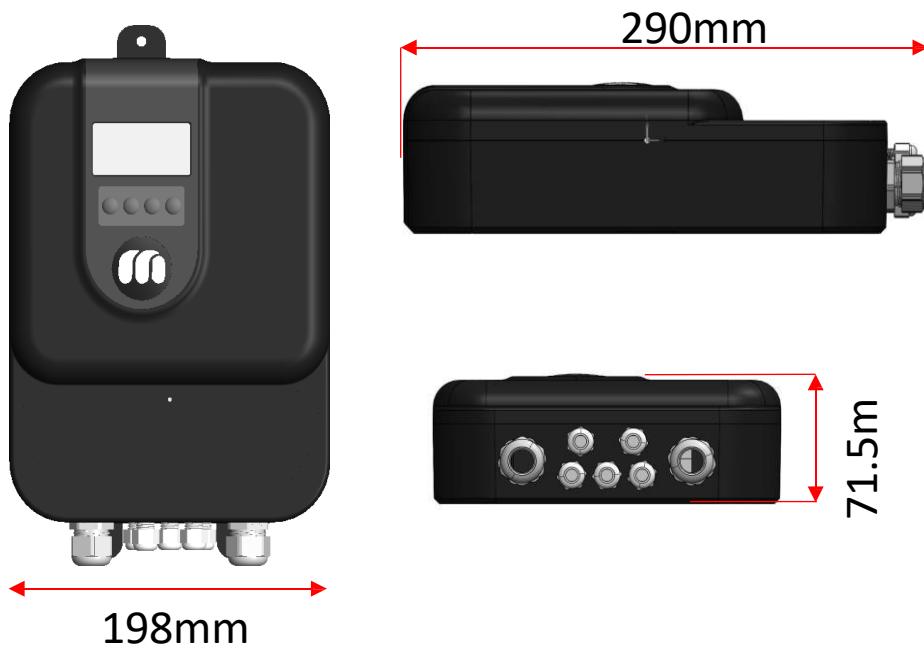



3.2.2 INSTALLATION DRAWINGS FOR NON-CONDUCTIVE PIPE

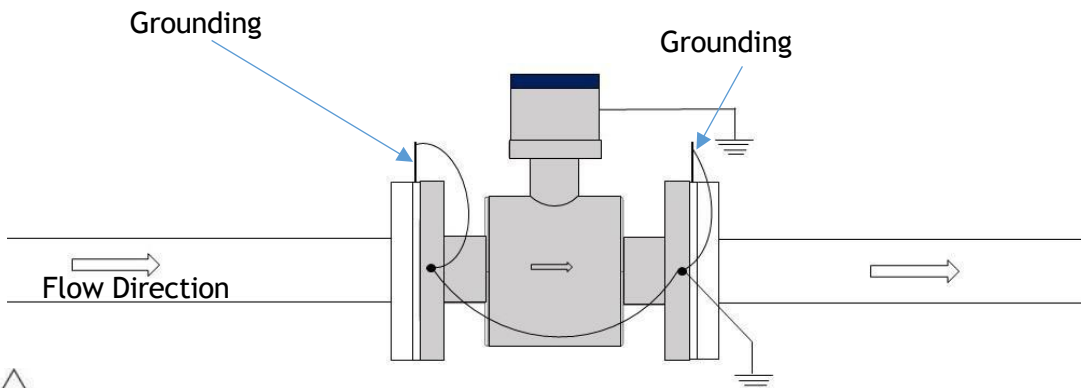

CAUTION

Make sure to connect the earth wires like the picture shows. If you don't, the meter might not work right.

INSTALLATION STEPS



WARNING!

Only trained workers should install this product, and they must follow all the rules for buildings.

1. Clean all flange surfaces well, making sure to remove any old gasket material or adhesive
2. Check all flange surfaces for any bending, dents, or other problems that might stop a good seal.
3. Use new bolts, nuts, and strong washers. Before putting them in, apply lubricant to the bolt threads, nuts, washer sides, and under the bolt head. This helps spread pressure evenly on the seal. Be careful not to get any lubricant on the liner or gasket.
4. Place the new gasket in the middle of the liner surface. Make sure the gasket doesn't stick out into where the liquid flows.
5. Use a torque wrench to tighten the bolts in three stages: first 30%, then 60%, and finally 100%. Tighten them in a repeating pattern.



3.2.3 FLOW SENSOR DIMENSIONS

ANSI CLASS 150 FLANGED SENSOR OVERALL DIMENSION

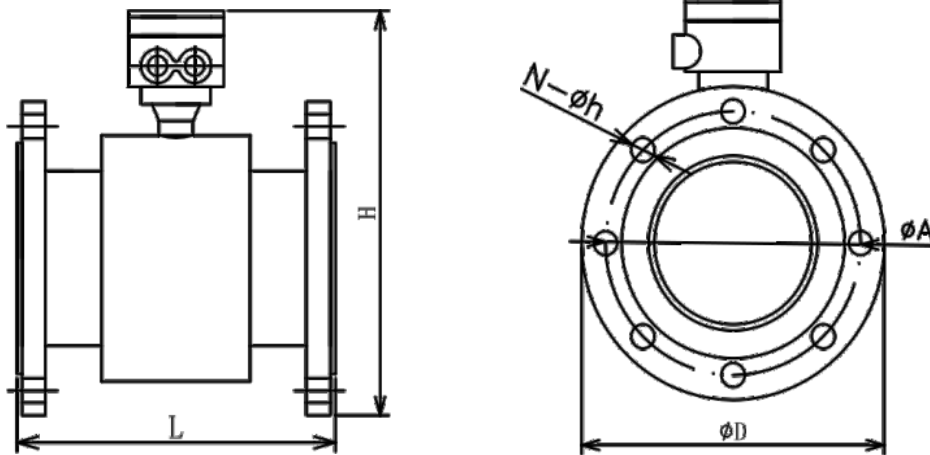

PIPE SIZE	L	D	A	N- Øh	H
DN 15	200	89	60.5	4-Ø15.7	217
DN20	200	99	69.9	4-Ø15.7	217
DN25	200	108	79.3	4-Ø15.7	220
DN32	200	118	88.9	4-Ø15.7	230
DN40	200	127	98.6	4-Ø15.7	240
DN50	200	152	120.7	4-Ø19.1	255
DN65	200	178	139.7	4-Ø19.1	280
DN80	200	190	152.4	4-Ø19.1	285
DN100	250	229	190.5	8-Ø19.1	315
DN125	250	254	215.9	8-Ø22.4	340
DN150	300	280	241.3	8-Ø22.4	370
DN200	350	343	298.5	8-Ø22.4	430
DN250	450	406	362	12-Ø25.4	495
DN300	500	483	432	12-Ø25.4	558
DN350	550	533	476.3	12-Ø28.4	608
DN400	600	597	540	16-Ø28.4	674
DN450	600	635	578	16-Ø32	718
DN500	600	699	635	20-Ø32	775



3.2.4 INSTALLATION

Installation of this product should be carried out by qualified professionals, ensuring compliance with all relevant local, state, and federal building codes. Begin by thoroughly cleaning all flange surfaces to remove any old gasket material and adhesive residue. Inspect the flange surfaces for any warping, pitting, or imperfections that could affect the seal. Use new bolts, nuts, and hardened washers, and lubricate them to ensure even stress distribution during installation. Be careful to avoid getting any lubricant on the liner .

INSTALLATION DIAGRAM

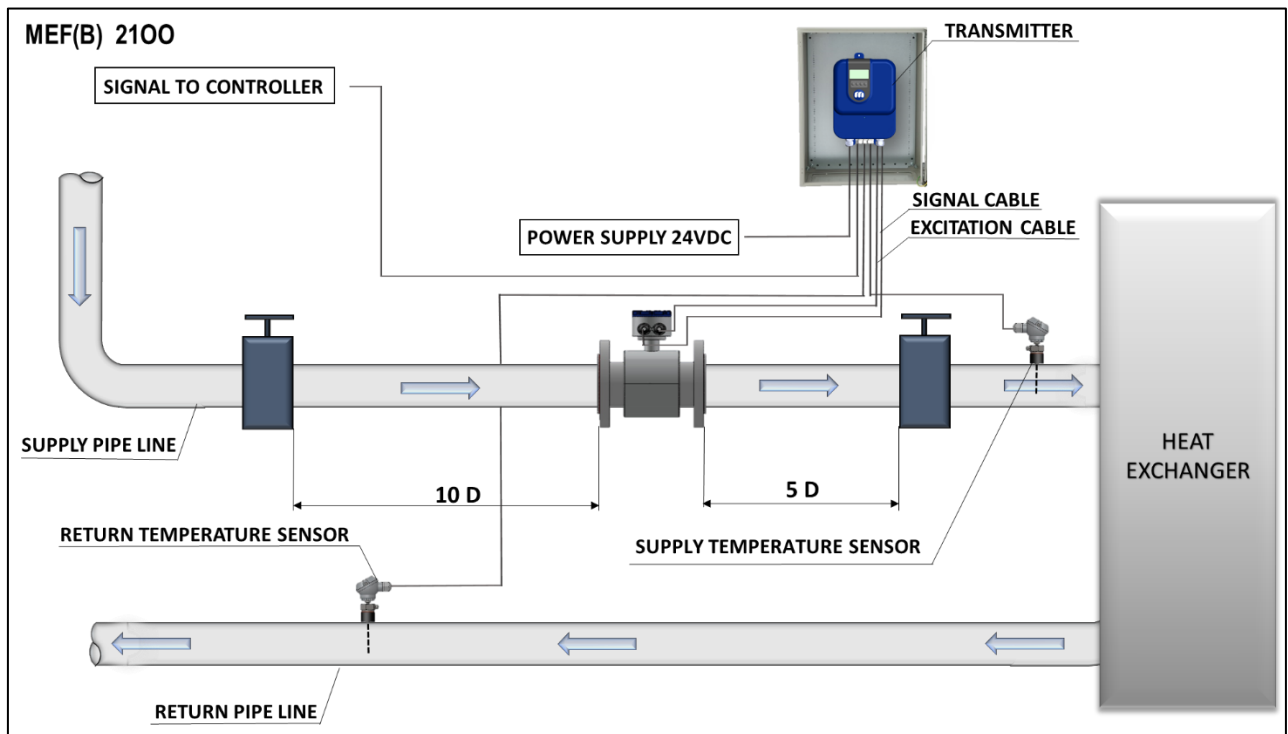

To ensure electromagnetic BTU meters work correctly, install the flow sensor head at the top of a horizontal pipe at the 12 o'clock position. The pipeline must be pressurized and filled entirely with clean water, without any air or particles. Air and particles act as insulators, disrupting the meters' electromagnetic induction and impairing their function. For vertical pipes, install the meter so water flows from bottom to top for optimal performance.



THERMOWELL INSTALLATION



IMPORTANT NOTE

It is crucial to ensure that no dirt or foreign materials enter the thermowells, as their presence could impact the system's thermal response.

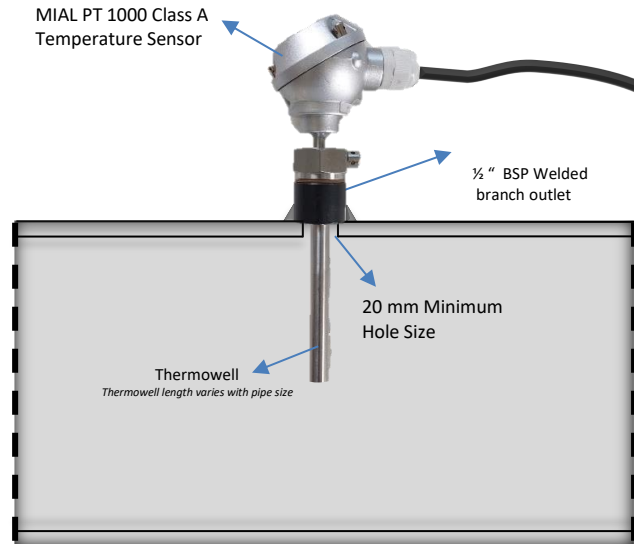

IMPORTANT NOTE!

3.2.3.1 The length of the thermowell varies depending on the pipe size.

3.2.3.2 Avoid using additional bushings to ensure the tip of the thermowell is properly inserted into the flow stream.

TEMPERATURE SENSOR INSTALLATION

The BTU meter comes with factory-matched temperature sensors, identified by serial numbers. These sensors, labeled as SUPPLY and RETURN, should be used exclusively with the designated BTU meter. Consult with MIALFactory before considering any alternative temperature sensors.

For proper installation, apply a thin layer of thermal compound to the temperature sensor. Carefully insert the sensor into the thermowell until it reaches the bottom of the cavity, then gently secure it with the retainer nut. Avoid over-tightening the nut, as the thermowell already seals the plumbing system. The nut's primary function is to ensure the sensor maintains contact with the bottom of the thermowell cavity.



4 ELECTRICAL CONNECTIONS

4.1 SAFETY INSTRUCTIONS



DANGER!

Only when power is switched off, we can do all the work about electrical connections. Please pay all attention to the power supply on the name plate!



DANGER!

Observe the national regulations for electrical installations!



DANGER!

For devices used in hazardous areas, additional safety notes apply; please refer to the Ex documentation.



WARNING!

Observe without fail the local occupational health and safety regulations. Any work done on the electrical components of the measuring device may only be carried out by properly trained specialists.



INFORMATION!

Look at the device nameplate to ensure that the device is delivered according to your order. Check for the correct supply voltage printed on the nameplate.



INFORMATION!

Connect the cable on connector with similar numeral marking

4.2 CONNECT SIGNAL AND MAGNETIC FIELD CURRENT CABLE



Danger !

Only when power is cut off we can connect signal and magnetic field current conductor.



Danger !

The equipment must be grounded in accordance with regulations so as to protect the operator from electrical shock.



Danger !

In case that equipment be used in explosion danger areas, special notes are given to explosion-proof instructions for safety tips.



Warning !

Please strictly observe local occupational health and safety regulations. Only those who have got properly trained are allowed to operate on the electrical equipment



4.2.1 CONNECTED TO POWER



It is mandatory to provide an individual 24 VDC, SMPS (Switch Mode Power Supply) for energizing the BTU meters. Additionally, it is essential to pull three-core wires (DC+, DC-, and ground) for the 24 VDC input power supply. As these are electromagnetic BTU meters, a proper input power supply with an appropriate ground is crucial for their correct operations



Danger !

The equipment must be grounded in accordance with regulations so as to protect the operator from electrical shock.



Danger !

There allows no permission of potential difference between measurement sensor and housing or converter protection ground.



Don't use bolts that hold the pipes together to make electrical connections. These bolts might not connect well because of paint or grease. Instead, use the special earth connections on the flange.



Grounding conductor should not transfer any disturbing voltage.



Grounding conductor is not allowed to be connected to other electrical.

4.2.2 LAYING ELECTRICAL CABLES CORRECTLY

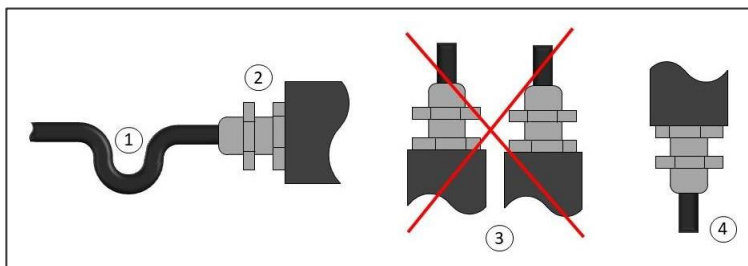

Keep the housing safe from dust and water

- i. Create a loop with the cable just before it reaches the housing.
- ii. Securely tighten the screw connection at the cable entry.
- iii. Always mount the housing with the cable entries facing downward.
- iv. Seal any unused cable entries with a plug.



4.2.3 EARTH CONNECTION



MEF(B) 2100 BTU meters detect small Electrical signals from electrodes when conductive fluid flows through their magnetic field, but electrical noise can interfere. To minimize noise, ensure the pipe, fluid, BTU meter body, and transmitter are all connected to the same earth ground with the earth cable as short as possible.

①

Provide a quality Earth ground connection to the meter. From best to worst, grounding options include (stranded wire 14-18 AWG):

②

Earth grounding rod driven into the ground

③

Earth wire connected directly to the building electrical service panel ground.



4.3 REMOTE TYPE WIRING INSTRUCTION

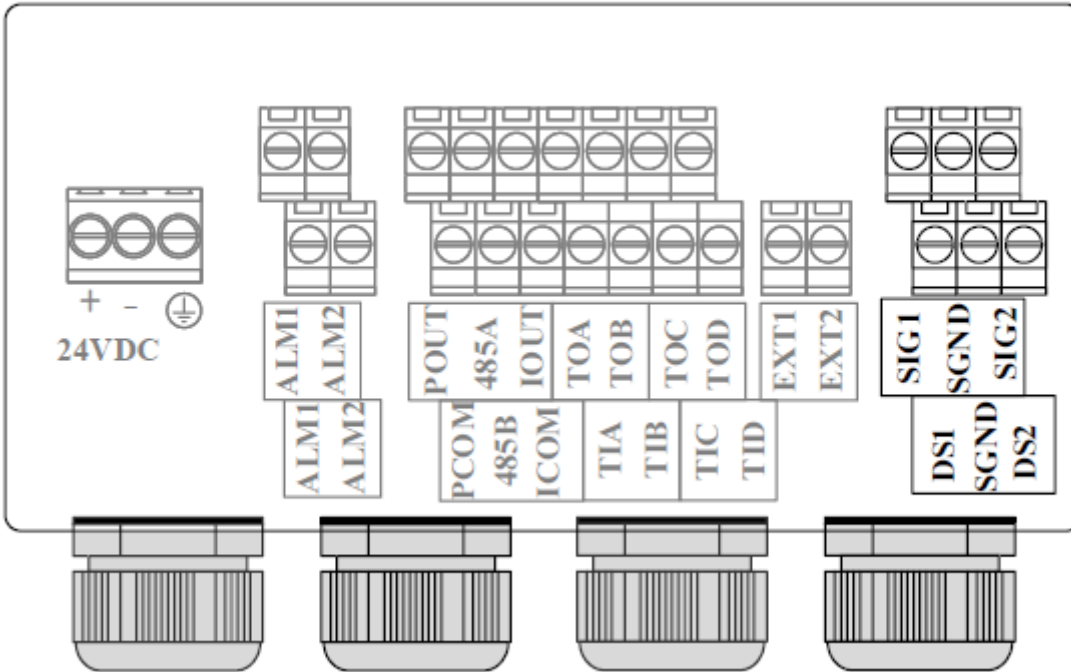

TIA	Entry Temperature Input (Supply)	TIB	Entry Temperature Input (Supply)
TIC	Entry Temperature Input (Supply)	TID	Entry Temperature Input (Supply)
TOA	Outlet Temperature Input (Return)	TOB	Outlet Temperature Input (Return)
TOC	Outlet Temperature Input (Return)	TOD	Outlet Temperature Input (Return)
SIG 1	Signal 1	SGND	Signal Ground
SIG2	Signal 2	DS1	Exciting Shielding 1
DS2	Exciting Shielding 2		
EXT1	Exciting Current +	EXT2	Exciting Current-
POUT	Frequency Output +	PCOM	Frequency Output Ground
IOUT	Current Output +	ICOM	Current Output Ground
485 A		485 A	
ALM1	Alarm	ALM2	Alarm
ALM1	Alarm	ALM2	Alarm



4.3.1 TEMPERATURE SENSOR INPUT CONNECTION

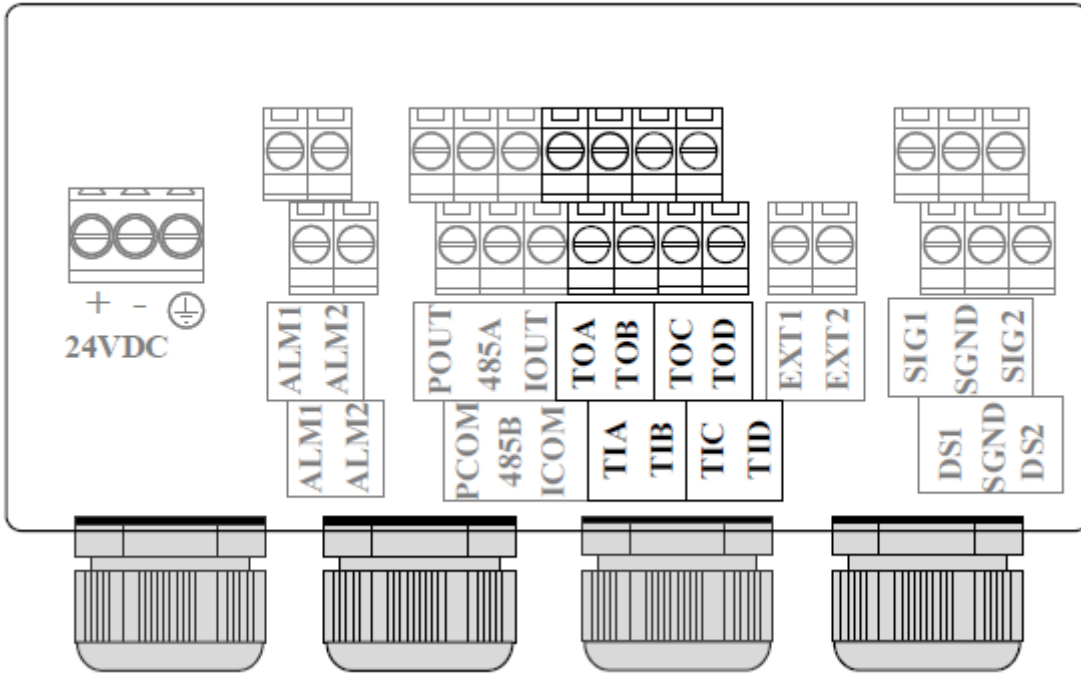

Supply and return water temperature input

- TIA,TIB,TIC,TID: Supply water temperature sensor inputs PT1000
- TOA,TOB,TOC,TOD: Return water temperature sensor inputs PT1000

Four wire heating resistance wiring

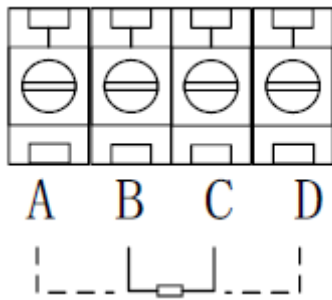

Note: two wire heating resistors are connected to BC terminal, while AB is connected to CD.



4.3.2 OUTPUT CONNECTION

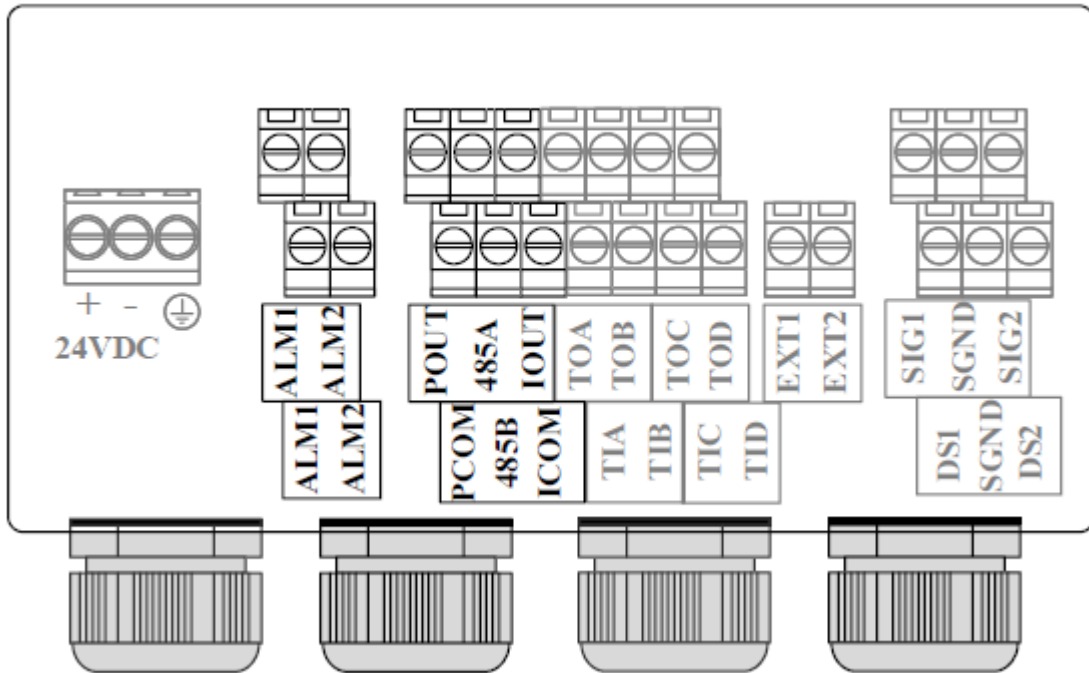

Current Output

- IOUT、ICOM: 0-20mA output
- Active mode: when load $R_L \leq 750\Omega$; $I_{max} \leq 22mA$
- Current flow percent

Communication output

- 485A、485B: 485 Serial communication output ;
- CCOM: 485 Serial communication ground ;
- Agreement: ModBus-RTU
- Pulse, Frequency and Alarm output
- ALM1,ALM2: Alarm output terminals
- POUT,PCOM : Pulse/frequency output terminals
- Active mode: High 24V, 5mA drive current
- Output electrical isolation: photoelectric isolation, isolation voltage: >
- 1000VDC ;

Scale:

- Frequency output: Frequency 2KHz(configurable 0-5kHz) Corresponding

to the upper limit of the flow range;
Pulse output: corresponding flow rate volume of each pulse
(configurable), output Pulse width: 0.1ms ~100ms, duty cycle 1:1,
Fmax <= 5000 cp/s ;

Elementary diagram:

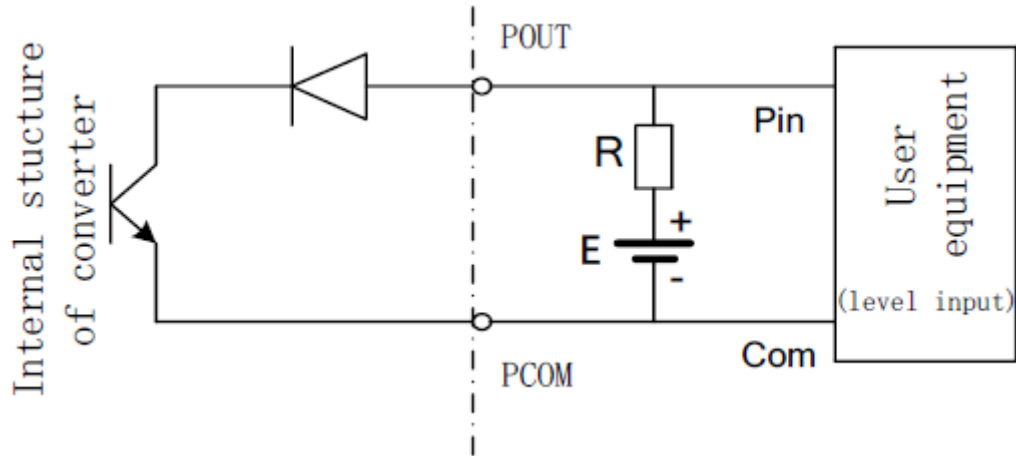

Additional remarks : pulse output for OC gate output, need external power supply.
General counter all wear resistance, signal can be directly connected to the counter.

Manufacturer recommendations: upper pull resistance R is recommended to use 2 k, 0.5 W resistor, another power E recommended 24 v dc power supply.

4.4 MEF(B) 2100 WIRING DIAGRAM AND MODBUS REGISTER DETAILS

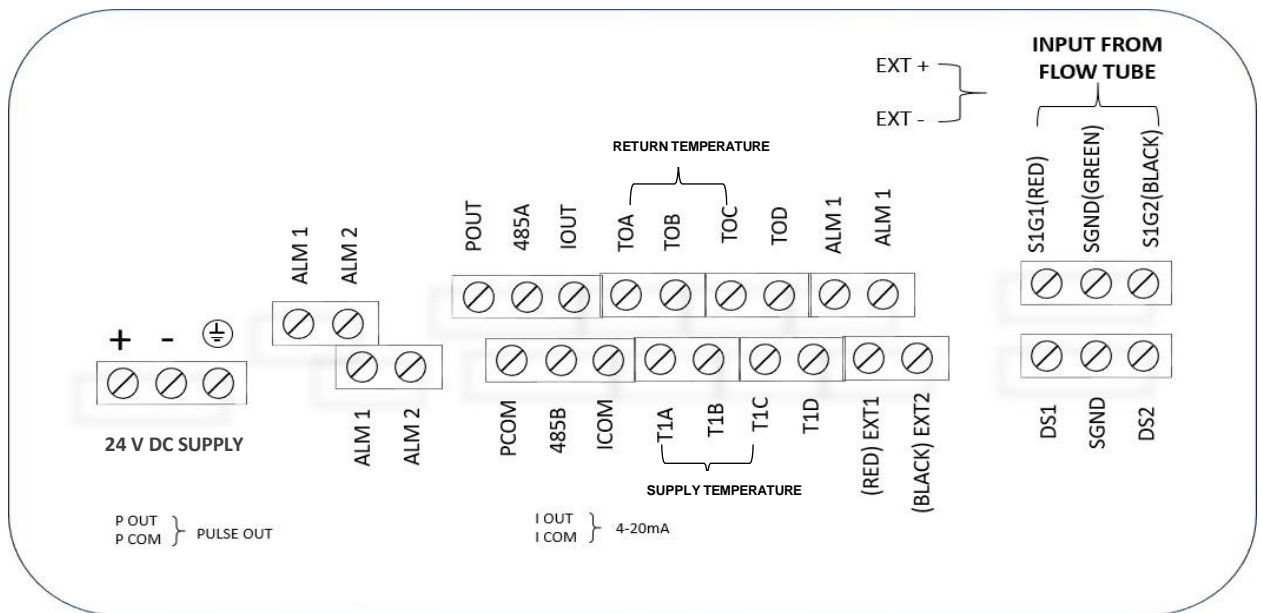

MEF(B) 2100 (REMOTE) BTU METER WIRING DIAGRAM



4.5 MEF(B) 2100 MODBUS CONFIGURATION DETAILS OF BTU METER TO BMS

Function Code	Details	Register Address	Modbus Register	Register Type
04 : Input Register	Supply Temperature	0122	30122	Float
	Return Temperature	0124	30124	Float
	Cold Energy Rate	0120	30120	Float
	Cold Energy Total	0130	30130	Integer
	Flow Rate	0100	30100	Float
	Flow Total	0108	30108	Decimal

Parity	: None Word
Length	: 8
Stop Bit	: 1

*NB :- Flow Total = 30108 + [30110 / 1000]
{ were; 30110- Decimal point of flow total register }

NB :- Energy Rate :- The "-" symbol followed by a digit denotes the cold instant rate in the Modbus register

*NB :- Energy Total = 30130 + [30132 / 1000]

Note: If your BMS register address starts from '0', please decrement '1' value from every register.

Example: flow rate register is 30100 then it should be configured as 30101

5. START UP

5.1 SWITCHING ON THE POWER

Please verify the instrument installation before powering it on. Ensure the following

- The meter is installed in compliance with safety standards.
- The power supply connection follows the relevant regulations.
- The electrical connections to the power supply are correct.
- The converter's back cover is securely tightened.
-

5.2 CONVERTER STARTUP

Measuring instrument consists of measuring sensor and signal converter, the supply has been already in a state of putting-in-service.

All the operation data and engineering contents have been set according to customer order. It will have a self-check after turning on the power supply. After that, measuring instrument will immediately begin to measure and display the current values.

Startup picture

BTU screen

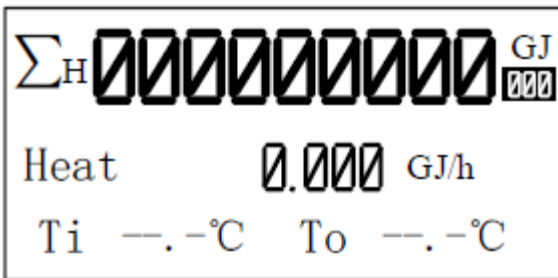

Flow screen

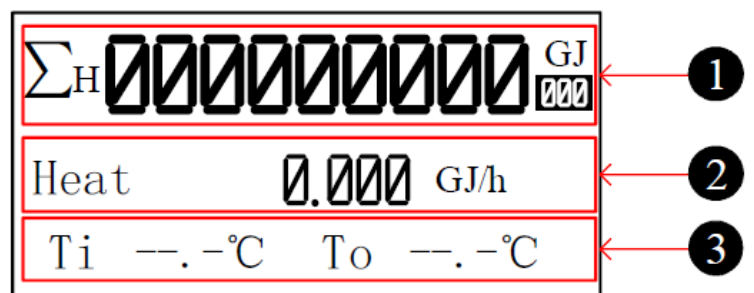
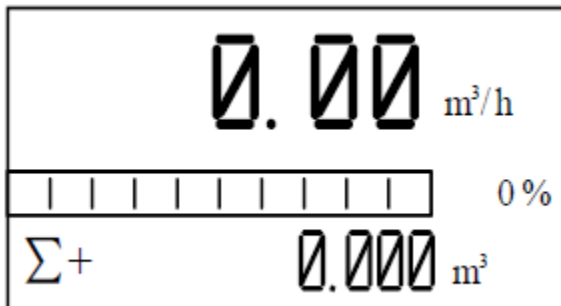

6. OPERATION

6.1 BTU display and operation Button

1. Energy line 1

Default : Accu heat

Optional : Accu heat, Accu cold and Heat.

Optional (loop) : Accu heat, Accu cold, Heat and OFF.

2. Energy line 2

Default : Heat

Optional : Heat, Tin and Tout, Tin, Tout, TD, Flow, Accu heat, Accu cold, Accu fwd, Accu rev, Accu net, Flow vel, MT, Shut num, Shut time, Run time and Real time.

Optional (loop) : Heat, Tin and Tout, Tin, Tout, TD, Flow, Accu heat, Accu cold, Accu fwd, Accu rev, Accu net, Flow vel, MT, Shut num, Shut time, Run time, Real time and OFF.

3. Energy line 3

Default : Tin and Tout

Optional : Tin and Tout, Tin, Tout, TD, Flow, Accu heat, Accu cold, Accu fwd, Accu rev, Accu net, Flow vel, MT, Shut num, Shut time, Run time, Real time and Heat.

Optional (loop) : Tin and Tout, Tin, Tout, TD, Flow, Accu heat, Accu cold, Accu fwd, Accu rev, Accu net, Flow vel, MT, Shut num, Shut time, Run time, Real time, Heat and OFF.

Tips: Heat-related parameters can press key to switch between.

Heat display can press buttons to switch the screen to Flow display.

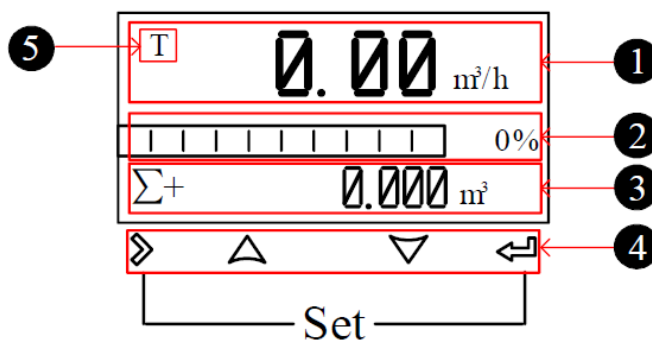



6.2 Flow display and operation Button

Flow line 1

Default : Flow

Optional : Flow, Accu fwd (Σ +: Positive flow accumulation), Accu rev (Σ -: Negative flow accumulation) and Accu net (Σ : Net flow accumulation).

Optional (loop) : Flow, Accu fwd, Accu rev, Accu net and OFF.

2. Flow line 2

Default : Flow bar

Optional : Flow bar, Accu fwd, Accu rev, Accu net, Flow vel (current flow rate) and MT (current conductivity).

Optional (loop) : Flow bar, Accu fwd, Accu rev, Accu net, Flow vel, MT and OFF.

3. Flow line 3

Default : Accu fwd

Optional : Flow bar, Accu fwd, Accu rev, Accu net, Flow vel and MT.

Optional (loop) : Flow bar, Accu fwd, Accu rev, Accu net, Flow vel, MT and OFF.

Tips:

1. You can modify the parameters of [flow/energy line 1/2/3] and [flow/energy line 1/2/3 loop] in flow configuration 12, and the cycle interval of each parameter is 10s.
2. When alarm occurs, the cycle interval of the alarm information (including empty pipe, high flow alarm, low flow alarm, overrun pulse limit alarm and overrun flow limit) screen is 5S and the duration is 2S. This information occupies flow line 2 and 3 in the display screen, as shown in the following figure.

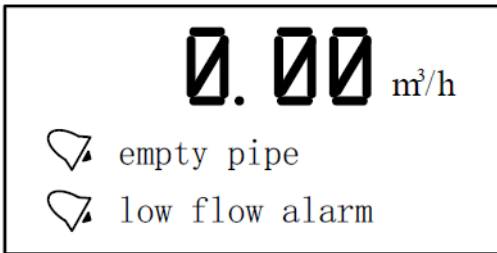

4 Operation keys: mechanical keys

Signal	Measuring Mode	Menu Mode	Function Mode	Data Mode
➤	-	switch menu categories	-	Data right shift
↵	Switch accumulative amount	Switch menu subclass	confirmation	Confirm data
△ ▽	-	-	selection	Change data
➤ + ↵	Enter menu	Exit menu	-	-

Test Flag

The test flow rate is disabled by default (allowing the test parameter to be set to "N"). When the test parameter is allowed to be set to "N", the test flag "T" is not displayed. When the test flow rate is turned on (allowing the test parameters to be set to "Y"), the test flag "T" is displayed in the upper left corner of the main interface.

6.3 Flow parameter display interface

Press and hold the button △ for 8 seconds on the ma

➤ to exit.

Fw:F99H1001	P1
Flow=0.000	m ³ /h
Span=35.0000	m ³ /h
V=0.0000m/s	Per=0 %
Sv=0.00 mv	DN=50
S0=0.00 mv	MT=3200
MTtrip=828	Stat=Empt
V0=0.0000	m/s



P1: First page

Parameter	Meaning
Fw	Program version number
Flow	Instantaneous flow rate
Span	Range
V	Velocity of flow
Per	Hundred components
Sv	Signal mv
DN	Caliber
S0	Zero point mv
MT	Real time conductivity conversion rate
MTrip	Air traffic control threshold
Stat	Air traffic control status
V0	Zero correction flow rate

Press the key  on the first page of the flow parameter display interface to switch to the second page, as shown in the following figure.

Fw:F99H1001	P2
Ks=1.00000	Kc=7.27092
Kf=1.00000	PGA=X3
Ia=0.2500A	EX=6.25Hz
Fr=0	Max=2000
EQ=1.000L/P	
ADDR=8	BAUD=9600

P2 : The second page

Parameter	Meaning
Fw	Program version number
Ks	Sensor coefficient
Kc	Converter coefficient
Kf	Fullness coefficient
PGA	Gain
Ia	Exciting current
EX	Excitation frequency
Pls	Pulse output type
Max	Upper frequency limit
EQ	Pulse output equivalent
ADDR	Correspondence addresses
BAUD	Baud rate

Press the key Δ on the second page of the flow parameter display interface to switch to the third page, as shown in the following figure.

```

Fw:F99H1001          P3
TiL=      0      TiH=      0
Ti=       0 (1000.0 Ω)
ToL=      0      ToH=      0
To=       0 (1000.0 Ω)
dh=0.000      kJ/kg
    
```

P3 : The third page

Parameter	Meaning
Fw	Program version number
Ks	Sensor coefficient
TiL	Lower limit code value of inlet temperature
TiH	Upper limit code value of inlet temperature
Ti	Instantaneous code value of inlet temperature
ToL	Lower limit code value of outlet temperature
ToH	Upper limit code value of outlet temperature
To	Instantaneous code value of outlet temperature
Dh	Enthalpy difference

6.4 Report display interface

Press the key \triangleright on the main interface to enter the report display interface. Press the key \triangleleft to modify the report type, energy/flow type, etc.

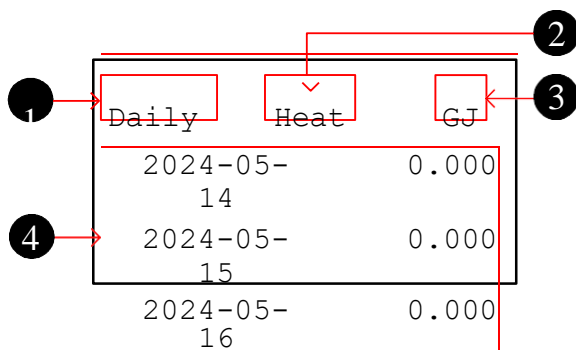

- Report type Default : Daily
Optional : Daily,Monthly, Yearly.



2. Energy/Flow type

Default : Heat Optional : Heat,Cold,Fwd.Flow,Rev.Flow.

3. Flow/Heat/Cold/ unit

Default : GJ/ m3 Optional :

Energy : GJ,kcal,Mcal,BTU,MBTU,Tonh,kWh,MWh,KJ,MJ, Flow :
m3,kg,t,gal,lgal,Mgal,ft3,bbbl,lbbl,Obbl,L

4. Report content

Press keys Δ ∇ to browse the report

6.5 Operating instruction

Parameter selection and adjustment



Press and \Leftarrow together , enter into parameter setting interface . Password need to be input by then

Initial users password: 200000 (used for modifying the user level parameter) Initial manufacture password:100000 (used for modifying the manufacture level parameter)

Initial manufacture password:300000 (to set up parameter quickly)

After entering the configuration parameters , the parameters can be modified by the following operation :

User can conduct the switch operation in the menu by pressing the button , switch among the parameter item of menu by pressing the \Leftarrow button, and store a modified parameter value at the same time , adjust the parameter value by pressing the Δ and ∇ buttons.

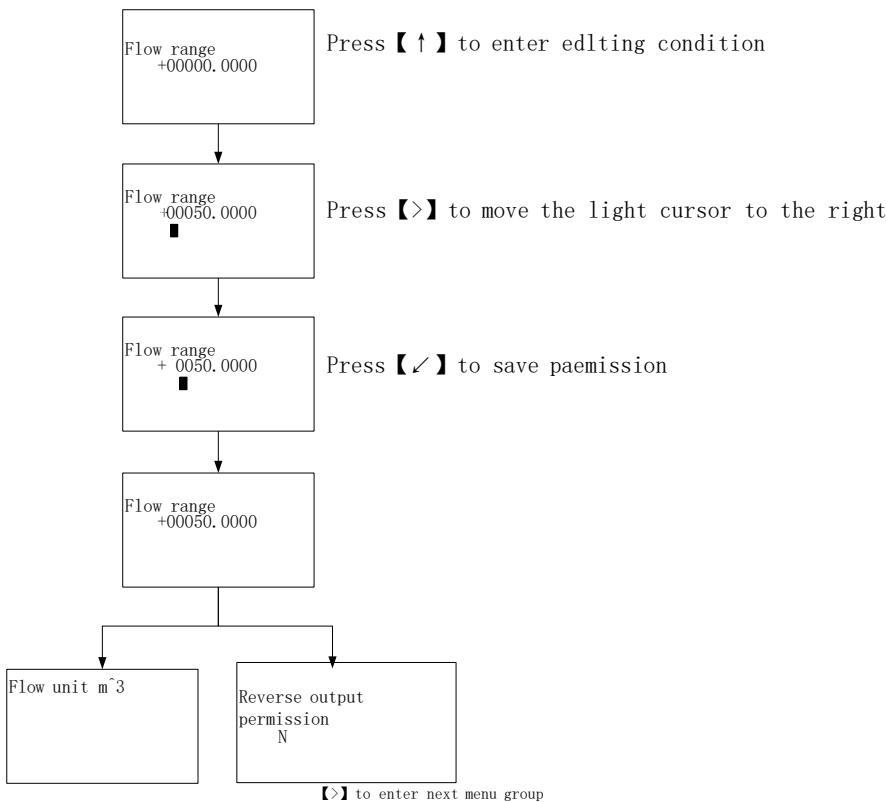

press \Leftarrow to move
the next parameter



Flow setup and analog output menu

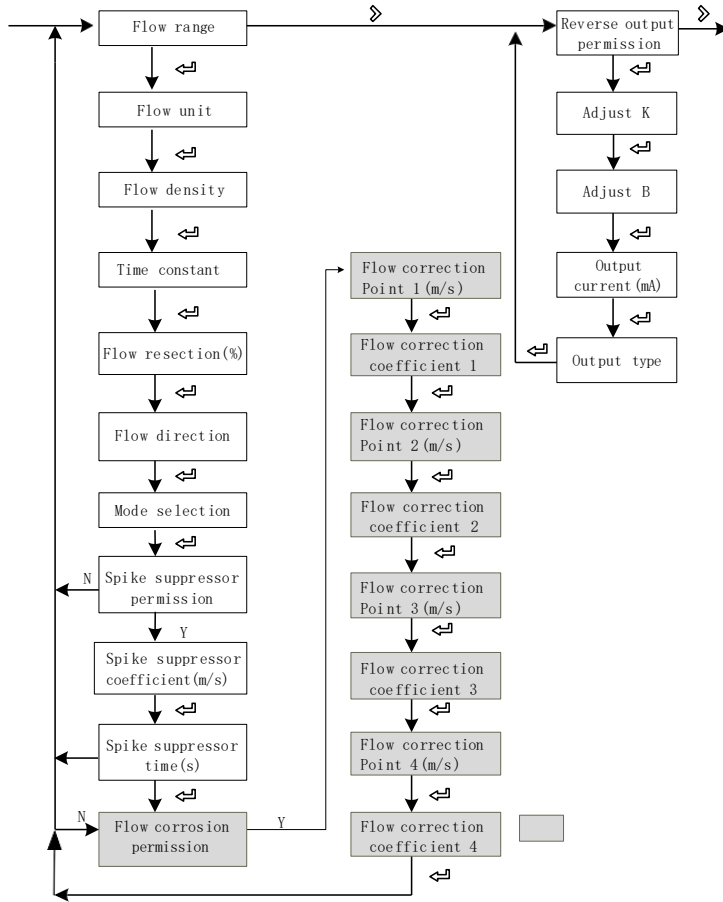

Note: it only display under the circumstance of manufacturer password

Pulse output and total set menu

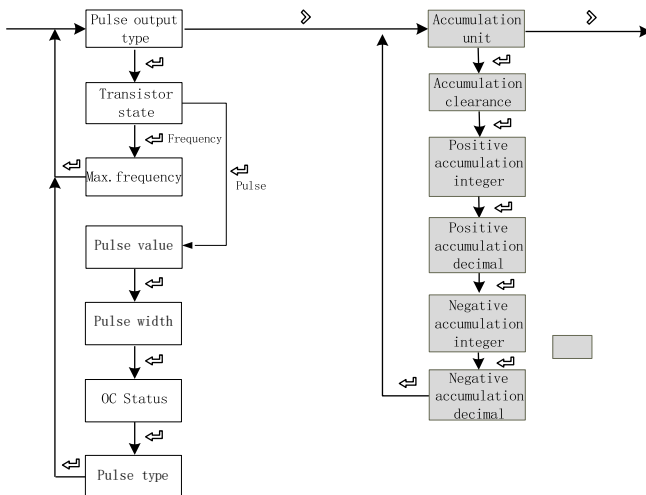

Note: it only display under the circumstance of manufacturer password

Alarm setup menu

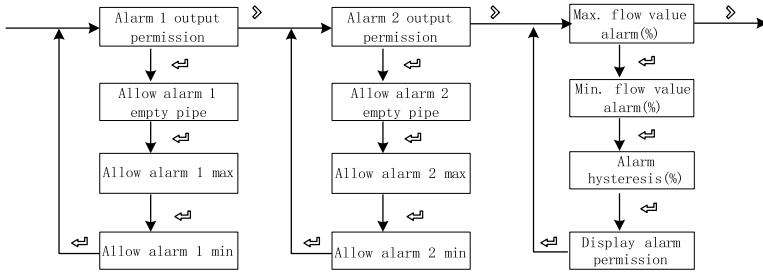

Thermal function menu

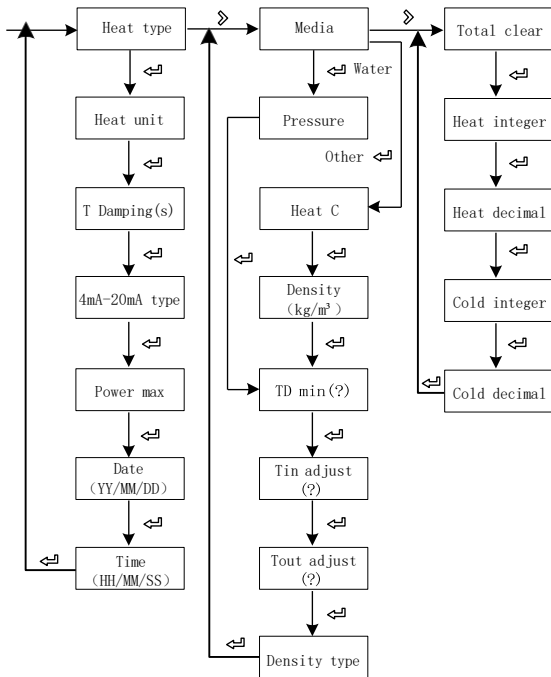



6.6 Configuration details

NO.	Parameter	Setting mode	Password level	Parameter range	Default
1-Flow rate					
1-0	Flow range	Figure	User	0-99999	35.000
	Set the maximum flow limit value. Used to calculate the frequency, output current limit calculation; Alarm threshold calculation, etc				
1-1	Flow unit	Option	User	L、m ³ 、Kg、t、gal、 lgal、Mgal、ft ³ 、bbl、 lbbbl、 Obbl/s、m、h、d	m ³ /h
	Choose L, m3, gal, lgal such as volume unit, the density will not participate in calculation; Choose Kg, t, such as mass unit, need to cooperate with 1-2 density parameter.				
1-2	Fluid density	Figure	User	0.000-99.000	1.000
	Used to calculate the mass flow rate, QM =ρVM when flow volume unit is volume unit t, this parameter will not be displayed. Density of the unit : g/cm ³				
1-3	Time constant	Figure	User	0-99S	2s
	Damping coefficient of the filter, select the parameters of the selected period of time as the average of the instantaneous flow				
1-4	Flow resection	Figure	User	0-10%	1%
	Flow volume is regarded as zero if it is below the setting value Zero means not remove				
1-5	Flow direction	Option	User	Positive, Negative	Positive
	Used to change the direction of flow, when the user signal lines negative pole and positive pole are reverse connection, or reverse sensor installation, use this feature				
1-6	Mode selection	Option	User	Positive,Negative, Bidirection	positive
	Set the direction of the flow measurement, forward direction indicates only for forward direction measurement flow, reverse indicate only measure the reverse flow, two-way indicate two-way flow measurement				
1-7	spike suppressor permission	Option	User	Y、N	N
	Indicate whether to enable peak inhibition function, this function is applied to the operation condition of the larger jamming signal , is used to filter the jamming signal.When set to N doesn't show 1-8, 1-9 configuration screen.When the range of the signal pulse is greater than 1-8 sets parameters and the time duration is less than 1-9 set time, the system will consider it an interference signal and will not display and measure .				



	spike suppressor coefficient	Figure	User	0.001-9.999m/s	0.8
	The peak amplitude (it is not shown when peak inhibition allows configuration closing)				
1-9	spike suppressor time	Option	User	0-9999s	1
	Peak duration time(it is not shown when peak inhibition allows configuration closing)				
	Flow correction permission	Option	User	Y、 N	N
1-10	<p>Indicates whether start using flow nonlinear correction function. In principle, used for small flow rate less than (0.5 m/s) linear adjustment</p> <p>The functional design with 4 period of correction, is divided into four flow point and correction coefficient. The corresponding velocity of correction point must meet : Correction point 1 ≥ Correction point 2 ≥ Correction point 3 ≥ Correction point 4 ≥ 0.</p> <p>Correction calculation is conducted on the original sensor flow coefficient curve correction, therefore, should be closed nonlinear correction function, mark sensor coefficient. Then allow the nonlinear correction function, according to the nonlinear of sensor, setting correction coefficient, piecewise corrected. If the coefficient is right, no need to calibration.</p> <p>The original velocity stand for the real standard velocity, the revised flow velocity is called modified velocity, the modified computation formula is as follows:</p> <p style="padding-left: 40px;">At the interval of the modified point 1 > The original flow velocity ≥ The modified point 2 The modified flow velocity = Correction factor 1 × The original flow velocity</p> <p style="padding-left: 40px;">At the interval of the modified point 2 > The original flow velocity ≥ The modified point 3 The modified flow velocity = Correction factor 2 × The original flow velocity</p> <p style="padding-left: 40px;">At the interval of the modified point 3 > The original flow velocity ≥ The modified point 4 The modified flow velocity = Correction factor 3 × The original flow velocity</p> <p style="padding-left: 40px;">At the interval of the modified point 4 > The original flow velocity ≥ 0 The modified flow velocity = Correction factor 4 × The original flow velocity</p> <p>Note: when set the modified point, should keep the following relationship. Modified point 1 > Modified point 2 > Modified point 3 > Modified point 4 > 0 The intermediate value of Correction coefficient is 1.0000, if the correction coefficient is greater than 1 , then increase the flow velocity ; if the correction coefficient is less than 1 , then decrease the flow velocity.</p>				
1-11	Flow correction point 1	Figure	Factory	0.0-99.999	0
	Flow rate modified point 1, when The flow rate function shut down , this parameter does not display.				
1-12	Flow correction coefficient 1	Figure	Factory	0.0-99.999	1.000
	Flow rate correction factor 1, when The flow rate function shut down , this parameter does not display.				



1-13	flow correction point 2	Figure	Factory	0.0-99.999	0
	Flow rate modified point 2, when The flow rate function shut down , this parameter does not display.				
1-14	Flow correction coefficient 2	Figure	Factory	0.0-99.999	1.000
	Flow rate correction factor 2, when The flow rate function shut down , this parameter does not display.				
1-15	Flow correction point 3	Figure	Factory	0.0-99.999	0
	Flow rate modified point 3, when The flow rate function shut down , this parameter does not display.				
1-16	Flow correction coefficient 3	Figure	Factory	0.0-99.999	1.000
	Flow rate correction factor 3, when The flow rate function shut down , this parameter does not display.				
1-17	Flow correction point 4	Figure	Factory	0.0-99.999	0
	Flow rate modified point 4, when The flow rate function shut down , this parameter does not display.				
1-18	Flow correction coefficient 4	Figure	Factory	0.0-99.999	1.000
	Flow rate correction factor 4, when The flow rate function shut down , this parameter does not display.				
1-24	Flow velocity (m/s)	Figure	Factory	1.000-24.000	12.000
	Used to set the upper limit absolute value of the measured flow rate. The default flow velocity is 12m / s.				
2-Current output					
2-1	Adjust K	Figure	User	-99.999~99.999	1.000
	Used for adjusting the output current value , $I = Kx + B$				
2-2	Adjust B	Figure	User	-99.999~99.999	0.000
	Used for adjusting the output current value , $I = Kx + B$				
2-3	Output current	Display	User	0.00-20.00	--
	Display the current output of current value(mA)				
2-4	Output type	Display	User	Flow、Heat	Flow
	The current output type can be selected, and the default is flow.				
3-Pulse/frequency/alarm output					
3-0	Pulse output type	Option	User	Frequency、 Pulse 、 Alarm (integrated)	Frequency



Optional frequency, pulse equivalent/alarm output					
3-1	Transistor state	Option	User	High level、Low level	High level
	Optional High level and Low level output.				
3-2	Max. frequency	Figure	User	0-5000	2000
	Set the corresponding value of the instantaneous flow upper limit; when select for frequency output, this parameter display.				
3-3	Pulse value(L/P)	Option	User	0.001-999.999	1.0
	Set the cumulant that each pulse stands for; When selecting is the equivalent output, this parameter display.				
	When the flow type is selected, the pulse unit is (L / P), and the default is 1. When the heat type is selected, the pulse unit is (kWh / P), and the default is 0.1.				
3-4	Pulse width	Option	User	10ms、20ms、 50ms、100ms、 200ms、50%	100ms
	Set Pulse width.				
3-5	OC Status	Option	User	Passive、Active	Active
	The OC status can be selected, and the default is active.				
3-6	Pulse type	Option	User	Flow、Heat	Flow
	The pulse type can be selected, and the default is flow.				

4-Accumulation					
4-0	Accumulation unit	Option	Factory	m ³ 、kg、t、gal、lgal、 Mgal、ft ³ 、bbl、 lbbl、Obbl、L	m ³
	Accumulation unit.				
4-1	Accumulation clearance	Option	Factory	Y、N	N
	Clear accumulation amount				
4-2	Positive accumulation integer	Figure	Factory	0-999999999	0
	Set total positive integer part				
4-3	Positive accumulation decimal	Figure	Factory	0.0-0.999	0.0
	Set total positive decimal part				
4-4	Negative accumulation integer	Figure	Factory	0-999999999	0

	Set reverse total integer part				
4-5	Negative accumulation decimal	Figure	Factory	0.0-0.999	0.0
	Set reverse total decimal part				
4-6	Flow accu magnification	Option	Factory	X1、X10、X100、X1000、X10000	X1
	Set flow accu magnification				
4-7	Positive flow shutoff	Figure	Factory	0-99999.9999	00000.000
	Set positive flow power outage compensation				
4-8	Negative flow shutoff	Figure	Factory	0-99999.9999	00000.000
	Set reverse flow power outage compensation				

7-Alarm setup					
7-0	Max. flow value alarm	Figure	User	0-999.9%	100%
	Set the upper limit alarm value, measuring range percentage				
7-1	Min. flow value alarm	Figure	User	0-999.9%	0%
	Set the lower limit alarm value, measuring range percentage				
7-2	Alarm hysteresis	Figure	User	0-99.9%	1%
	Used to eliminate the alarm when the disturbance Upper limit elimination conditions: instantaneous flow is less than the upper limit alarm value – return difference Lower limit elimination conditions: instantaneous flow is greater than the upper limit alarm value + return difference				
7-3	Display alarm permission	Option	User	Y/N	N
	Allows the alarm message display onto to the main picture switch				
8-System					
8-0	Language	Option	User	Chinese/English	Chinese
	Set configuration display language				
8-1	Display accuracy	Figure	User	0-4	2
	The instantaneous volume of decimal digits				
8-2	Contrast				
	Contrast ratio of Liquid crystal display				



8-3	Modbus address	Figure	User	1-247	8
	Communication agreement instrument address Based on the RS485 protocol Modbus RTU				
8-4	Baud rate	Option	User	1200/2400/4800/9600/ 19200/38400/57600	9600
	Baud rate of serial communication verification mode				
8-5	Even-odd check	Option	User	NONE/ODD/ EVEN	NONE
	Serial communication verification mode of physical layer				
8-6	Byte order	Option	User	2-14-3、3-41-2、 4-31-2、1-23-4	2-14-3
	Byte switching order for serial communication at the physical layer				
8-8	User password	Figure	User	00000-999999	000000
	User-level password for viewing and modifying user-level parameter configurations, User initial password: 200000				
8-9	Factory password	Figure	Factory	00000-999999	000000
	Factory-level password for viewing and modifying user-level parameter configurations, Factory initial password: 100000				

8-16	Record interval	Figure	Factory	0000-9999	0010
	Set Record interval				
8-17	Remove card	Option	Factory	Y , N	N
	Set the Y indicator light to turn off, the card will stop being stored, and the card can be pulled out				
9- Empty tube paramet ers					
9-0	Empty pipe threshold value	Figure	Factor y	0-100%	50%
	Empty tube alarm judgement gate value				
9-1	Actual electrical conductivity	Display	Factor y		
	Display the measured conductivity equivalent of the fluid. For general natural water: equivalent < 200 when tube is full, when empty tube > 200 (the equivalent is related to the fluid conductivity and the length of measuring line , it is recommended double shielded wire is used when the wiring distance is 20m , otherwise it will affect empty detection function .				
9-2	Empty pipe check permission	Option	Factor y	Y , N	Y
	Set whether open empty detection function				
9-3	Empty pipe check max.	Figure	Factor y	0-9999	1200
	Measured conductivity equivalent value when the tube is empty, default values can be used for general natural water. which need to observe the empty wipe for special fluid is 9-1 value, write in 9-3				



9-4	Empty pipe check min.	Figure	Factory	0-9999	200
	Measured conductivity equivalent value when the tube is full, default values can be used for general natural water. which need to observe the empty wipe for special fluid is 9-1 value, write in 9-4				
9-5	Empty pipe check hysteresis	Figure	Factory	0-9999	30
	Hysteresis value for empty pipe check, default values can be used within 20 meters of the signal line.				
9-6	Empty pipe check num	Figure	Factory	01-10	05
	Set the number of empty pipe check. When the empty pipe signal of this number is continuously detected, an empty pipe alarm will be triggered.				

10-Sensor					
10-0	Sensor coding	Figure / symbol	Factory	16 digital	
	Used for identify sensors				
10-1	Factory ID number	Figure	Factory	6 digital	
	Identification number				
10-2	Diameter	Option	Factory	3-2000	50
	Sensor size				
10-4	Sensor coefficient	Figure	Factory	0-99.99999	01.00000
	The flowmeter coefficient was calibrated according to the actual flow volume by sensor manufacture				
10-6	Zero correction(m/s)	Figure	Factory	-9.9999~9.9999	+0.0000
	Sensor nonlinear correction when used for small flow (below 0.3 m/s) V is the real-time flow rate displayed above, V (after correction) = V (before correction) + zero correction value				
10-7	Excitation mode	Option	Factory	3.125Hz、6.25 Hz、12.5 Hz、25 Hz	6.25Hz
	The choice of excitation frequency: 3.125Hz、6.25Hz、12.5Hz、25 Hz				
10-9	Gain selection	Option	Factory	1/3/9	3
	Gain choice: adjust the gain can change the range of flow speed Gain adjustment : 1、3、9				
11-Test					
11-0	Allow test	Option	Factory	Y/N	N
	Set Y allow simulate velocity, the flag "T" is displayed in the upper left corner of the main interface, After the power failure automatically restored to N.				
11-1	Flow rate (m/s)	Figure	Factory	-99999.999~+999 99.999	1.000
	Set value of flow rate, "11-0 allow test" should be set to "Y"				



	Source code	Optio		Y/N	N
11-2	After setting Y, the original signal code will be displayed in the running screen. This screen also displays the firmware version and product serial number.				
	n Factory				
12-8	Energy line 2	Option	User	Heat, Tin and Tout, Tin, Tout, TD, Flow, Accu heat, Accu cold, Accu fwd, Accu rev, Accu net, Flow vel, MT, Shut num, Shut time, Run time, Real time	Heat
A parameter can be selected as the display parameter of energy line 2.					
12-9	Energy line 2 loop	Option	User	Heat, Tin and Tout, Tin, Tout, TD, Flow, Accu heat, Accu cold, Accu fwd, Accu rev, Accu net, Flow vel, MT, Shut num, Shut time, Run time, Real time, OFF	OFF
You can turn off or select another parameter as the loop display parameter of energy line 2.					
12-10	Energy line 3	Option	User	Heat, Tin and Tout, Tin, Tout, TD, Flow, Accu heat, Accu cold, Accu fwd, Accu rev, Accu net, Flow vel, MT, Shut num, Shut time, Run time, Real time	Tin and Tout
A parameter can be selected as the display parameter of energy line 3.					
12-11	Energy line 3 loop	Option	User	Heat, Tin and Tout, Tin, Tout, TD, Flow, Accu heat, Accu cold, Accu fwd, Accu rev, Accu net, Flow vel, MT, Shut num, Shut time, Run time, Real time, OFF	OFF
You can turn off or select another parameter as the loop display parameter of energy line 3.					



20-Heat unit and time configuration					
20-0	Heat type	Option	Factory	Auto/heat/cold	Auto
	Users choose heat type.				
20-1	Heat unit	Option	Factory	kW, MW, kJ/h, MJ/h, GJ/h , Mcal/h, kcal/h, BTU/h, MBTU/h, Ton	GJ/h
	Heat unit and total unit synchronization, in normal use, please carefully modify the parameters.				
20-2	T Damping(s)	Option	Factory	0-99	2
	Temperature filter damping, set the time constant for smoothing the temperature display.				
20-3	4mA~20mA type	Option	Factory	Flow/Power	Flow
	Select flow / power as the 4mA~20mA output type, power output to kW as the unit.				
20-4	Power max.(kW)	Option	Factory	0.001-999999	1000.00
	Set power upper limit value. For frequency, output current limit threshold calculation. When the 4mA~20mA output type is selected as the power, this parameter is displayed.				
20-7	Date(YY/MM/DD)	Option	Factory		
	Set the instrument date, YY/MM/DD followed by year / month / day.				
20-8	Time(HH/MM/SS)	Option	Factory		
	Set the instrument time, HH/MM/SS in turn, time / minute / second.				







21-Heat signal parameter					
21-0	Media	Option	Factory	Water/Other	Water
	Users choose to measure medium, water or other.				
21-1	Pressure	Option	Factory	0.6MPa/ 1.6MPa	0.6MPa
	Set water pressure value. Select water as the measuring medium, this parameter display.				
21-2	Heat C	Figure	Factory	1.00-100.00	4.20
	Set the specific heat capacity of the heat calculation of other media. When the measurement medium is selected as the other medium, this parameter is displayed.				
21-3	Density(kg/m ³)	Figure	Factory	100-9999.99	1000.00
	Set the density value of the heat calculation of other media. When the measurement medium is selected as the other medium, this parameter is displayed.				
21-4	TD min(°C)	Figure	Factory	0.0-3.0	0.2
	When the temperature difference between Tin and Tout is smaller than the set of small temperature difference, default no heat generation.				



21-6	Tin adjust(°C)	Figure	Factory	-3.0-3.0	0.0
	Adjust the supply temperature setting.				
21-7	Tout adjust(°C)	Figure	Factory	-3.0-3.0	0.0
	Adjust the return temperature setting.				
21-8	Density type	Option	Factory	Tin、Tout	Tin
	Users choose the density calculation method.				
21-9	Temperature unit	Option	Factory	°C、°F	°C
	Set Temperature unit.				

22-Heat accumulation					
22-0	Total clear	Option	Factory	Y、N	N
	Clear the cumulative total amount of heat and cold.				
22-1	Heat integer	Figure	Factory	0-999999999	
	Setting the total heat Integer part				
22-2	Heat decimal	Figure	Factory	0.0-0.999	
	Setting the total heat decimal part				
22-3	Cold integer	Figure	Factory	0-999999999	
	Setting the total cold Integer part				
22-4	Cold decimal	Figure	Factory	0.0-0.999	
	Setting the total cold decimal part				
22-5	Heat accu magnificent	Option	Factory	X1、X10、X100、X1000、X10000	X1
	Set heat accu magnificent				
22-6	Heat shutoff (GJ/h)	Figure	Factory	0-99999.9999	00000.0 000
	Set heat power outage compensation				
22-7	Cold shutoff (GJ/h)	Figure	Factory	0-99999.9999	00000.0 000
	Set cold power outage compensation				
23-Clear report					
23-0	Total clear	Option	Factory	Y、N	N
	Clear the total report.				

6.7 Quick setup menu

- Press on  and  at same time ,Instrument parameter is set at the interface.Password need to be input at this time.
- Quickly set the password : 300000
- The user can use the key  to switch between menu pages, use the key and key  to adjust the parameter value, then use the key  to confirm.
- The parameters that can be set are shown in the table below.
- After modification, move to the menu page [exit config], select Y and press on .

NO	Parameter words	Setting mode	Parameter range	default
1	Diameter(mm)	Option	3-2000	50
2	Flow range	Figure	0-99999	35.000
3	Sensor coefficient	Figure	0-99999	1.000
4	Zero correction	Figure	0-99999	0.0
5	Accumulation clearance	Option	Y、 N	N
6	Flow resection(%)	Figure	0-99%	1%
7	Time constant	Figure	0-99S	3s
8	Pulse output type	Option	Frequency、 Pulse 、 Alarm、	Frequency
9	Max. frequency	Figure	0~5000.0	2000.0
10	Pulse value (L/P)	Figure	0-999999.999	1.000

7 Functions

7.1 System information

Flow meter itself has the self-diagnosis function, in addition to the power supply and circuit board hardware failures, it can correctly provide the corresponding alarm message to the fault in general application .

Display position in measuring picture

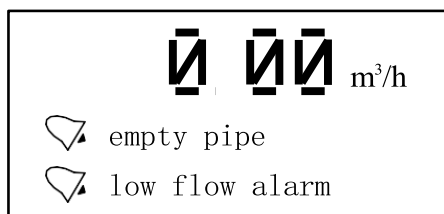

System information sheet

Display	Alarm content
empty pipe	Sensor empty pipe
high flow alarm	The current instantaneous flow rate exceeds the setting flow limit
low flow alarm	The current instantaneous flow rate is below the setting flow lower limit
overrun pulse limit alarm	The pulse output frequency exceeds the setting frequency upper limit
overrun flow limit	The current instantaneous flow rate exceeds the setting flow limit

7.2 Pulse/Frequency/Current output

Pulse equivalent output

It is mainly used for sensor manufacturer coefficient calibration and user measurement use. In the third way configuration parameter Settings:
Pulse equivalent corresponding cumulants, indicate each pulse corresponding to the relevant volume number .

For example :

Parameter setting as 0.1L/p

The current instantaneous flow 3.6m³/h

Number of pulses per second output is : $3.6 \times 1000 / 3600 / 0.1 = 10$

Notes :

When the parameter is set to 0.4L/p

The current instantaneous flow is 3.6m³/h

Number of pulses per second output is : $3.6 \times 1000 / 3600 / 0.4 = 2.5$



Encounter the above situation, the decimal part of 2.5 pulse will automatically get into the next second output, data loss will not happen.

The pulse equivalent shouldn't be set too small when the pipe flow is small, otherwise it will cause pulse output exceeds the limit, then the main screen will appear [overrun pulse limit alarm] system alarm information. Users need to reset pulse equivalent parameters. Similarly, when the pipe flow is small the selected pulse equivalent cannot too big, otherwise it will cause the instrument to output a pulse for a long time, cause measurement error. Pulse equivalent output is different from frequency output, pulse output will output a pulse when a pulse equivalent is accumulated enough, so the pulse output is uneven. Counter instrument should be used when measure pulse output, Frequency meter instrument shouldn't be used.

Frequency output

It is mainly used for manufacturer coefficient calibration and user measurement use. In the third group configuration parameters setting: frequency corresponding to instantaneous flow rate, upper frequency limit corresponding to max. flow rate.

Note: the maximum frequency set to 5000 Hz.

Current output

Mainly used for transmitting output to other intelligent instruments, such as: digital display table, recorder, PLC, DCS, etc.

The current output type : 0-20mA.

The current valve corresponding to Instantaneous flow rate , 20 mA corresponding to range limit, 0 mA corresponding to range limit.

Conversion

relationship Q real

time>0

$$I_{\text{realtime}} = \frac{Q_{\text{realtime}}}{Q_{\text{max}}} \times 16.00 + 4.00$$

Q real time<0

$$I_{\text{realtime}} = \frac{Q_{\text{realtime}}}{Q_{\text{max}}} \times 4.00 + 4.00$$

Unit : mA

Notice : Q real time Indicate the instantaneous flow rate Q MAX Indicate the current instrument range I real time Indicate Real time current value

7.3 Serial communication

This instrument provides a standard RS485 serial communication interface, using the international standard MODBUS-RTU communication protocol that supports 04 Read Input Registers command.

Register address

Parameter	Type	Address	Explanation
Instantaneous flow rate	float	100	
Instantaneous flow velocity	float	102	
Flow percentage	float	104	50 stands for 50%
Electric conductivity	float	106	
Forward flow accumulation of integer	ulong	108	
Forward flow accumulation of decimal	ulong	110	The decimal part magnifies 1000 times 123stand for 0.123
Reverse flow accumulation of integer	ulong	112	
Reverse flow accumulation of decimal	ulong	114	The decimal part magnifies 1000 times 123stand for 0.123
Real heat rate	float	120	
Water supply Temperature	float	122	
Return water temperature	float	124	
Heat accumulated integer	ulong	126	
Heat accumulated decimal	ulong	128	Decimal part magnification of 1000, 123 representatives 0.123
Cold accumulated integer	ulong	130	
Cold accumulated decimal	ulong	132	Decimal part magnification of 1000, 123 representatives 0.123
Heat unit	ushort	134	0x00: kW 0x01:MW 0x02: kJ/h 0x03: MJ/h 0x04: GJ/h 0x05: kcal/h 0x06: Mcal/h 0x07:BTU/h 0x08: MBTU/h0x09: Ton
Cumulative heat unit	ushort	135	0x00: kWh 0x01: MWh 0x02: kJ 0x03: MJ 0x04: GJ 0x05: kcal 0x06: Mcal 0x07:BTU 0x08: MBTU 0x09: Tonh

Note: float/ulong/long type data, Communication transmission in byte order 2-1-4-3; ushort type data Transmission in accordance with 2-1.

Communication configuration Mailing address : 1-247; Default address : 8;

Baud rate : 1200、2400、4800、9600、19200、38400、57600;

The default baud rate : 9600; Check: no check, odd parity, parity;

Default no check;

For 32-bit data (long plastic or floating point) arranged in the communication frame; Example : Long integer

16909060(01020304H) : 03 04 01 02

Floating number 4.00(40800000H) : 00 00 40 80

Readout real-time quantity floating-point communications, example:

Real time Floating point Numbers readout Send message : 08 04 00 63 00 02 81 4C

Return message : 08 04 04 22 6E 41 3F 79 61 (Instantaneous flow rate : 11.95)

Forward flow rate accumulate readout Send message : 08 04 00 6B 00 04 80 8C

Return message : 08 04 08 00 6C 00 00 00 7B 00 00 D6 8E (The cumulative integer :

108, Cumulative decimal : 0.123, Accumulation : 108.123)

7.4 Firmware upgrade instructions

- Connect the instrument and computer through RS485 serial communication interface, open [DFU firmware online upgrade] software, and click [next].
- Enter the [1/5 open upgrade package] interface, click the folder and select the given upgrade package file. The file name is: current version → upgrade version, and the format is [. dfu], such as [F99H1000 → F99H1001. dfu], then click [next]
- Enter the [2/5 communication configuration] interface and select [serial port], [communication address], [baud rate], [verification method] (It is consistent with the parameters set in the instrument).
- Enter the [3/5 connect instrument] interface, confirm that the [instrument string code] is the firmware version of the current instrument, and click [next].
- Enter the [4/5 upgrade warning] interface and enter the [upgrade authorization code] provided by the manufacturer. To upgrade the 485 communication firmware online, you should first adjust the instrument screen to [11-2 Source code], select [Y], and then click [next] of DFU software.
- Enter the [5/5 download firmware] interface, wait for the firmware upgrade to display [finish], and click [finish]. Enter the instrument configuration interface and confirm the firmware version in the upper right corner.

7.5 Operation instructions of flow correction function

In principle, used for small flow rate less than (0.5 m/s) linear adjustment. Correction calculation is conducted on the original sensor flow coefficient curve correction, therefore, should be closed nonlinear correction function, mark sensor coefficient. Then allow the nonlinear correction function, according to the nonlinear of sensor, setting correction coefficient, piecewise corrected. If the coefficient is set right, no need to calibration.

The functional design with 4 period of correction, is divided into four flow point and correction coefficient.

The corresponding velocity of correction point must meet :

Correction point 1 \geq Correction point 2 \geq Correction point 3 \geq Correction point 4 \geq 0. The original velocity stand for the real standard velocity, the revised flow velocity is called modified velocity, the modified computation formula is as follows:

- The original flow velocity \geq The modified point 1 The flow velocity keeps unchangeable.
- At the interval of the modified point 1 $>$ The original flow velocity \geq The modified point 2
The modified flow velocity = Correction factor 1 \times The original flow velocity
- At the interval of the modified point 2 $>$ The original flow velocity \geq The modified point 3
The modified flow velocity = Correction factor 2 \times The original flow velocity
- At the interval of the modified point 3 $>$ The original flow velocity \geq The modified point 4
The modified flow velocity = Correction factor 3 \times The original flow velocity
- At the interval of the modified point 4 $>$ The original flow velocity \geq 0
The modified flow velocity = Correction factor 4 \times The original flow velocity Note: when set the modified point, should keep the following relationship Modified point 1 $>$ Modified point 2 $>$ Modified point 3 $>$ Modified point 4 $>$ 0 The intermediate value of Correction coefficient is 1.0000, if the correction coefficient is greater than 1 , then increase the flow velocity ; if the correction coefficient is less than 1 , then decrease the flow velocity.

Case1:

The original flow velocity:0~0.4m/s, correction factor changes to 1.2.

Parameter setting

Flow correction point 1	Flow correction point 2	Flow correction point 3	Flow correction point 4
0.4	0	0	0
Flow correction coefficient 1	Flow correction coefficient 2	Flow correction coefficient 3	Flow correction coefficient 4
1.2	1	1	1



The modified flow velocity

The original flow velocity	The modified flow velocity
0~0.4m/s	1.2 × The original flow velocity

Case2:

The original flow velocity:0.2~0.4m/s, correction factor changes to 0.9. The original flow velocity:0.4~0.5m/s, correction factor changes to 1.1.

Parameter setting

Flow correction point 1	Flow correction point 2	Flow correction point 3	Flow correction point 4
0.5	0.4	0.2	0
Flow correction coefficient 1	Flow correction coefficient 2	Flow correction coefficient 3	Flow correction coefficient 4
0.9	1.1	1	1

The modified flow velocity

The original flow velocity	The modified flow velocity
0.2~0.4m/s	0.9 × The original flow velocity
0.4~0.5m/s	1.1 × The original flow velocity

Case3:

The original flow velocity:0.1~0.2m/s, correction factor changes to 0.9. The original flow velocity:0.2~0.3m/s, correction factor changes to 1.1. The original flow velocity:0.3~0.4m/s, correction factor changes to 0.8.

Flow correction point 1	Flow correction point 2	Flow correction point 3	Flow correction point 4
0.4	0.3	0.2	0.1
Flow correction coefficient 1	Flow correction coefficient 2	Flow correction coefficient 3	Flow correction coefficient 4
0.8	1.1	0.9	1

Parameter setting

The modified flow velocity

The original flow velocity	The modified flow velocity
0.1~0.2m/s	0.9 × The original flow velocity
0.2~0.3m/s	1.1 × The original flow velocity
0.3~0.4m/s	0.8 × The original flow velocity

Case4:

The original flow velocity:0.1~0.2m/s, correction factor changes to 0.9. The original flow velocity:0.3~0.4m/s, correction factor changes to 1.1.

Parameter setting

Flow correction point 1	Flow correction point 2	Flow correction point 3	Flow correction point 4
0.4	0.3	0.2	0.1
Flow correction coefficient 1	Flow correction coefficient 2	Flow correction coefficient 3	Flow correction coefficient 4
1.1	1	0.9	1

The modified flow velocity

The original flow velocity	The modified flow velocity
0.1~0.2m/s	0.9 × The original flow velocity
0.3~0.4m/s	1.1 × The original flow velocity

Case5:

The original flow velocity:0~0.2m/s, correction factor changes to 0.9. The original flow velocity:0.2~0.3m/s, correction factor changes to 1.1. The original flow velocity:0.3~0.4m/s, correction factor changes to 0.8. The original flow velocity:0.4~0.5m/s, correction factor changes to 0.9.

Parameter setting

Flow correction point 1	Flow correction point 2	Flow correction point 3	Flow correction point 4
0.5	0.4	0.3	0.2
Flow correction coefficient 1	Flow correction coefficient 2	Flow correction coefficient 3	Flow correction coefficient 4
0.9	0.8	1.1	0.7

The modified flow velocity

The original flow velocity	The modified flow velocity
0~0.2m/s	0.7 × The original flow velocity
0.2~0.3m/s	1.1 × The original flow velocity
0.3~0.4m/s	0.8 × The original flow velocity
0.4~0.5m/s	0.9 × The original flow velocity

7.6 TF card operation

Insert the TF card into the slot, the indicator light will light up, and the TF card will start storing data. In configuration 8-17, change the removed card to Y, the indicator light goes off, and the TF card stops storing. In configuration 8-16, the recording interval can be modified, ranging from 1 to 9999 seconds

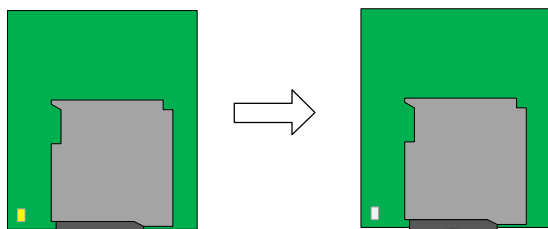

Storage status



Annexure - 1: Flow Chart

SIZE(mm)	FLOW RANGE & VELOCITY TABLE						
	0.1 M/S	0.5 M/S	1 M/S	3 M/S	5 M/S	10 M/S	12 M/S
DN10	0.02	0.14	0.28	0.84	1.41	2.82	4.24
DN15	0.06	0.31	0.63	1.9	3.18	6.36	9.54
DN20	0.11	0.56	1.13	3.39	5.65	11.31	16.96
DN25	0.17	0.88	1.76	5.3	8.83	17.67	26.5
DN32	0.28	1.44	2.89	8.68	14.47	28.95	43.42
DN40	0.45	2.26	4.52	13.57	22.62	45.23	67.85
DN50	0.7	3.53	7.06	21.2	35.34	70.68	106.02
DN65	1.19	5.97	11.94	35.83	59.73	119.46	179.19
DN80	1.8	9.04	18.09	54.28	90.47	180.95	271.44
DN100	2.82	14.13	28.27	84.82	141.37	282.74	424.11
DN125	4.41	22.08	44.17	132.53	220.89	441.78	662.68
DN150	6.36	31.8	63.61	190.85	318.08	636.17	954.27
DN200	11.31	56.54	113.09	339.29	565.48	1131	1696.47
DN250	17.67	88.35	176.71	530.14	833.57	1767.2	2650.72
DN300	25.44	127.23	254.46	763.4	1272.4	2544.7	3817.03
DN350	34.63	173.18	346.36	1039.1	1731.8	3463.6	5195.41
DN400	45.23	226.19	452.38	1357.2	2262	4523.9	6785.83
DN450	57.25	286.27	572.55	1717.7	2862.8	5725.6	8588.32
DN500	70.68	353.42	706.85	2120.6	3534.3	7068.6	10602.9
DN600	101.8	508.93	1017.9	3053.6	5089.4	10179	15268.2
DN700	138.5	692.72	1385.4	4156.3	6927.2	13854	20781.6
DN800	181	904.77	1809.6	5428.7	9047.8	18096	27143.4
DN900	229	1145.1	2290.2	6870.7	11451	22902	34353.3
DN1000	282.7	1413.7	2827.4	8482.3	14137	28274	42411.5



MIAL[®]
INSTRUMENTS PVT.LTD.
Measuring & Beyond

USA OFFICE ADDRESS

MIAL INSTRUMENTS PVT. LTD.
Downtown Republic Center
325 N. St.Paul Street, Suite 3100
Dallas 75201, Texas, USA

FACTORY ADDRESS

MIAL INSTRUMENTS PVT. LTD.
856/ 6 GIDC
Makarpura, Vadodara 390010, Gujarat, India
+91-9913449547/9913449548

Email : info@mialinstruments.com
www.mialinstruments.com



**MIAL
INSTRUMENTS**
Measuring & Beyond

856/6, GIDC MAKARPURA, VADODARA - 390010
Phone : +91-9913449547 / +91-9913449548
E-MAIL : info@mialinstruments.com
WWW : www.mialinstruments.com