

| INSTALLATION & OPERATION MANUAL

MULR Ultrasonic Level Sensors



MIAL[®]
INSTRUMENTS PVT.LTD.
Measuring & Beyond

www.mialinstruments.com

MULR

Ultrasonic Level Sensors

Preface

- Thank you for purchasing our product.
- This manual is about the various functions of the product, wiring methods, setting methods, operating methods, troubleshooting methods, etc.
- Please read this manual carefully before operation, use this product correctly to avoid unnecessary losses due to incorrect operation.
- After you finish reading, please keep it in a place where it can be easily accessed at any time for reference during operation.



NOTE!

Modification of this manual's contents will not be notified as a result of some factors, such as function upgrading. We try our best to guarantee that the manual content is accurate, if you find something wrong or incorrect, please contact us. The content of this manual is strictly prohibited from reprinting or copying.

About this manual

- Please submit this manual to the operator for reading.
- Please read the operation manual carefully before applying the instrument. On the precondition of full understanding.
- This manual only describes the functions of the product. The MIAL Instruments pvt.ltd. Does not guarantee that the product will be suitable for a particular use by the user.

Warnings and symbols used



HAZARD!

If not taken with appropriate precautions, will result in serious personal injury, product damage or major property damage.



WARNING!

Pay special attention to the important information linked to product or particular part in the operation Manual



CAUTION!

Disregarding these instructions can result in damage to the device or to parts of the operator's plant.



INFORMATION!

These instructions contain important information for the handling of the device.



Table of Contents

Preface	1
About this manual.....	1
1. INTRODUCTION	3
1.1 PURPOSE OF THE MANUAL.....	3
1.2 OPERATING PRINCIPLE	5
1.3 TECHNICAL SPECIFICATIONS	5
2. DEVICE DESCRIPTION.....	7
2.1 SCOPE OF DELIVERY	7
2.2 NAMEPLATE OF THE METER	7
3. INSTALLATION GUIDE	8
3.1 INSTALLATION GUIDE	8
3.2 MEASURING RANGE SELECTION.....	9
3.3 LIQUID MEASUREMENT	10
4. ELECTRICAL CONNECTIONS.....	25
4.1 SAFETY INSTRUCTIONS.....	25
4.2 WIRING	25
5. OPERATIONS	25
5.1 INTERFACE IN OPERATION MODE	27
5.2 INTERFACE INTRODUCTION.....	28
5.3 OPERATION MENU.....	29



1. INTRODUCTION

1.1 PURPOSE OF THE MANUAL

Overview:

Welcome to the user manual for the Mial MULR Ultrasonic Level Sensors. This comprehensive guide is designed to assist operators, maintenance personnel, and system integrators in understanding, installing, operating, and maintaining the Mial MULR Ultrasonic Level Sensors effectively.

Objectives:

Clarification of Functionality: This manual aims to provide a clear understanding of the principles and functionality of the Mial MULR Ultrasonic Level Sensors. Users will gain insights into its design, components, and how it precisely measures fluid flow.

Guidance for Installation:

Step-by-step instructions and considerations for proper installation are provided to ensure optimal performance. Safety precautions are emphasized to create a secure working environment.

Training and Familiarization:

Users will be guided through the features, controls, and indicators of the flow meter, facilitating efficient operation. This section aims to serve as a valuable training resource for users at various experience levels.

Maintenance and Troubleshooting Assistance:

Learn about routine maintenance procedures and effective troubleshooting techniques. This manual empowers users to address common issues and perform regular maintenance to enhance the longevity of the Mial MULR Ultrasonic Level Sensors.

Intended Audience:

This manual is intended for operators, maintenance personnel, and system integrators involved in the installation, operation, and maintenance of the Mial MULR Ultrasonic Level Sensors. It is suitable for both novice users seeking basic guidance and experienced professionals looking for specific details.

Important Notes:

Please read through the manual carefully, adhering to safety guidelines and following instructions precisely. If any uncertainties arise during the installation, operation, or maintenance processes, seek assistance from qualified personnel or our customer service / support team.

Reference to Other Documentation:

Refer to the accompanying technical specifications document for in-depth details about the Mial MULR Ultrasonic Level Sensors.. Additional resources can be found on our website.

Intended use



CAUTION!

Responsibility for the use of the measuring devices with regard to suitability, intended use and



corrosion resistance of the used materials against the measured fluid lies solely with the operator.



INFORMATION!

The manufacturer is not liable for any damage resulting from improper use or use for other than the intended purpose



INFORMATION!

As the product is updated constantly, there is no guarantee the product specification and installation is fully consistent with the latest products. The part change contains but not limited to the following sections

1. Blind zone, performance parameter, function, structure, shape, color and so on.
2. Software function, structure, display mode, operating habits and so on.

And please be noted:

1. For any operation of the hardware, it must be done after the power off. It is not within the warranty if short-circuit or the other faults due to the operation with electricity.
2. Please power off before opening the cover, and it is not allowed liquid flow into the meter.

For ultrasonic level meter, under normal circumstances, after installing it correctly based on manual, you only

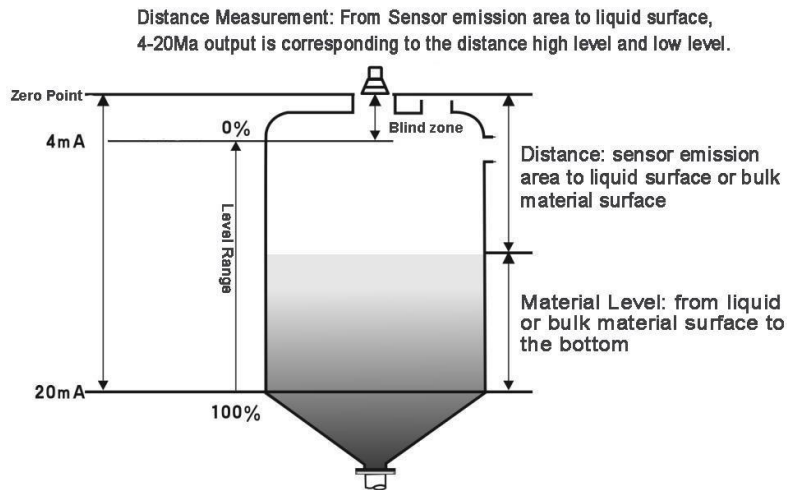

need to set the following parameters, the meter will working normally.

DIAGRAM OF DISTANCE MEASUREMENT

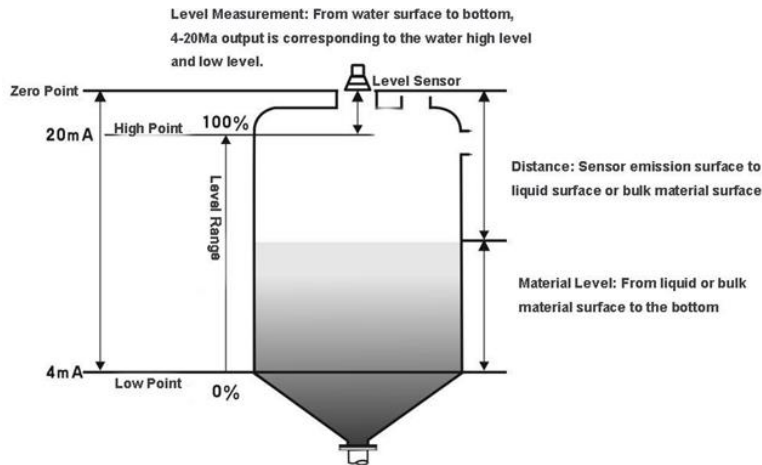

DIAGRAM OF LEVEL MEASUREMENT

Diagram Description:

★ This is an important reminder, please read carefully and do exactly as required.

▲ This is a general hint, please read carefully in case any trouble in use.

1.2 OPERATING PRINCIPLE

An ultrasonic level meter operates on the principle of sound wave reflection. It emits high-frequency ultrasonic pulses from a transducer towards the surface of the material being measured, such as a liquid or solid. These pulses travel through the air, hit the surface, and reflect back to the transducer. The device then calculates the time taken for the echo to return and, based on this time delay, determines the distance between the sensor and the material surface. By knowing the distance, the level of the material can be accurately measured.

Ultrasonic level meters are widely used for non-contact measurement and are suitable for various applications, including liquids, slurries, and bulk materials.



1.3 TECHNICAL SPECIFICATIONS

Fluid types

Clean liquids

Level Range

4m, 6m, 8m, 12m

Accuracy

0.5% - 1.0%

Resolution

3mm or 0.1%

Measurement parameters

Display Percentage,Current Data,Distance

Certification

Calibration certification

Electronics

Display

LCD

Enclosures

Aluminium

Enclosure IP rating

IP65

Power supply

24 VDC

Use SMPS when employing AC power

Ambient temperature

Transmitter: -4°F to 140°F (-20°C to 60°C)

Sensor: -4°F to 176°F (-20°C to 80°C)

Standard output

Analog output : 4 to 20 mA ,250 Ω maximum load

Network Connection (Optional)

Modbus RS 485

Cable

10 Meter

Probe Materials

Standard: PVC

Optional: ABS,PTFE

Sensor IP rating

Sensor :IP68

*Specifications are subject to change without prior notice



2 DEVICE DESCRIPTION

2.1 SCOPE OF DELIVERY



INFORMATION!

Do a check of the packing list to make sure that you have all the elements given in the order



INFORMATION!

Inspect the packaging carefully for damages or signs of rough handling. Report damage to the carrier and to the local office of the manufacturer.

2.2 NAMEPLATE OF THE METER

Ultrasonic Level Meter	
Model: MULR-XM	
Accuracy : 0.5%	
Output : 4-20mA	
Power : 24VDC	Range :XM
Protection Class : _____	
Serial No : _____	
 MIAL [®] INSTRUMENTS PVT.LTD. <i>Measuring & Beyond</i>	



3. INSTALLATION

3.1 INSTALLATION GUIDE

LEVEL RANGE :

When we do the model selection, the meaning of the level range is very important, please check the following schematic.

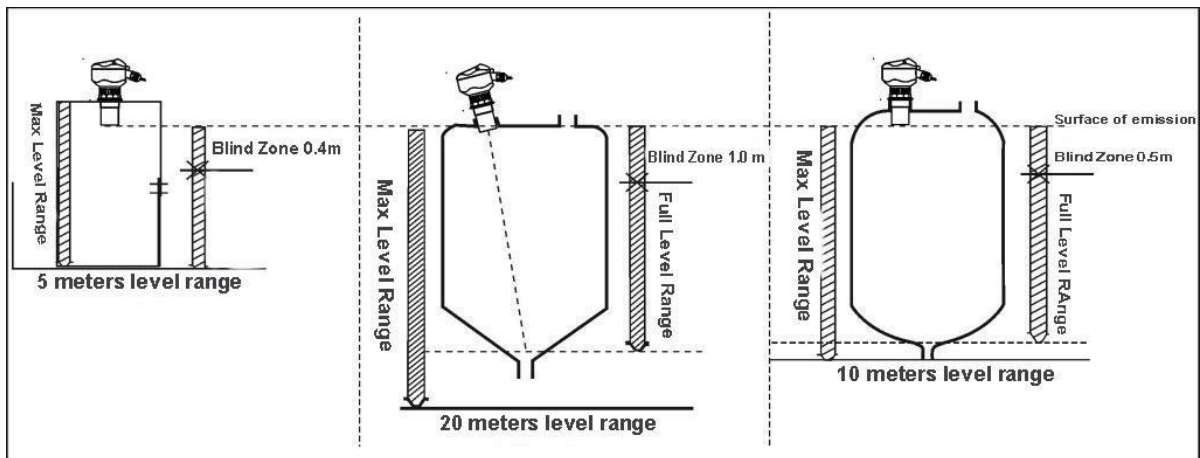

BEAM ANGLE AND FALSE ECHO

Ultrasonic waves are focused through the probe, the pulse wave is just as the light from a flashlight, the farther away from the probe, the greater the diffusion area.

Any object in the emission angle (such as pipe, bracket, weld seam, reinforcing rib, stirring propeller and wall-hanging object) will cause strong false echo especially the object near the probe.

For example: It is 9 times stronger for the false echo caused from the probe 6 meters away from the pipe than the probe 18 meters away from the same pipeline.

Try to make the axis of the sensor perpendicular to the surface of the media and avoid any other objects in the emission angle. such as: pipelines and brackets.



3.2 MEASURING RANGE SELECTION

The measuring range depends on the range of the ultrasonic probe. The range of probes relate to the working environment, the medium, the temperature and so on.

According to the table below, you can choose what level range you need.

Liquid Surface Status	Attenuation Multiples	Percentage of Attenuation	To Enlarge the level range
Stable	0dB	0%	No need
Small Wave	5...10dB	50~67%	2 times of level range
Large wave (such as with mixing impeller)	10...20dB	90%	3 times of level range

Bulk material	Attenuation Multiples	Percentage of Attenuation	To Enlarge the level range
Hard, rough material (such as granulated Rubber)	40dB	99%	10 times of level range
Soft Material(Such as coal, cement powder, fly ash)	40...60dB	99~99.9%	Not Suitable

Dust	Attenuation Multiples	Percentage of Attenuation	To Enlarge the level range
No	0dB	0%	No need
A Little	5dB	50%	2 times of level range
Large	5...20dB	50~90%	3 times of level range

Feeding Material	Attenuation Multiples	Percentage of Attenuation	To Enlarge the level range
No	0dB	0%	No need
A little	5...10dB	50~67%	2 times of level range
Large	10...40dB	67~99%	3 times of level range



Mist/Vapor	Attenuation Multiples	Percentage of Attenuation	To Enlarge the level range
No	0dB	0%	No need
A little	5...10dB	50~67%	2 times of level range
Large	10...20dB	67~90%	3 times of level range

Steam	Attenuation Multiples	Percentage of Attenuation	To Enlarge the level range
No	0dB	0%	No need
A little	5...10dB	50~67%	2 times of level range
Large	10...20dB	67~90%	3 times of level range

The temperature difference between the probe and the medium	Attenuation Multiples	Percentage of Attenuation	To Enlarge the level range
≤20°C	0dB	0%	No need
≤40°C	5...10dB	50~67%	2 times of level range
≤80°C	10...20dB	67~90%	3 times of level range

Signal attenuation calculation: if there are many situations, it is necessary to accumulate these several cases to get the amount of signal attenuation.

- With a little Feeding 5...10dB
 - With a little steam 5...20dB
 - Probe and medium surface temperature difference ≤40°C 5...10dB
 - A small amount of feed 5...10dB
 - A small amount of steam 5...20dB
 - Probe and dielectric surface temperature difference ≤40°C 5...10db
- Total: Minimum 15dB, Max 40dB

In such case, if the actual maximum measurement range is 5 meters, then we need to choose 50 m level range ultrasonic level meter,

3.3 LIQUID MEASUREMENT

3.3.1 FLAT-TOPPED TANKS/CANS

Flat-topped cans generally have a very short neck, the base surface of the neck is the bottom surface of the flange; On the premise of below:

Neck length ≤ 60mm;

The pipe diameter ≥ 100mm;

The inner wall of nozzle is flat without burr and convex object, then just need the emission surface of the probe (after installation) 3cm lower than the bottom surface of the flange.

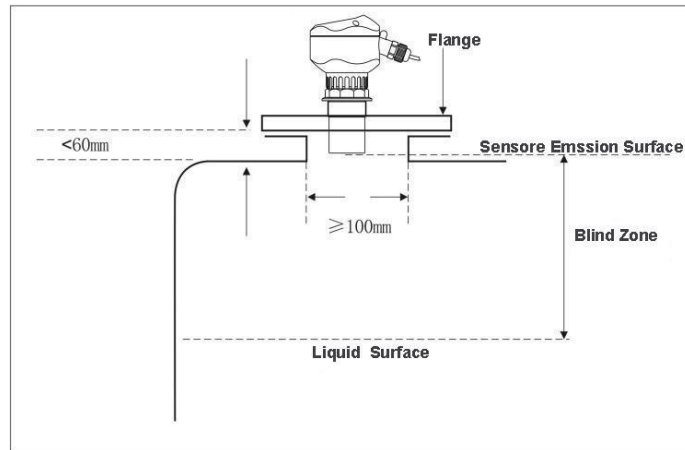

Flange Connection, installed in a very short neck

The ideal place is to install the instrument directly on the flat-topped container without using a neck, and the circular openings on the container can be fixed enough for the flange or universal flange. The probe was launched under the base level.

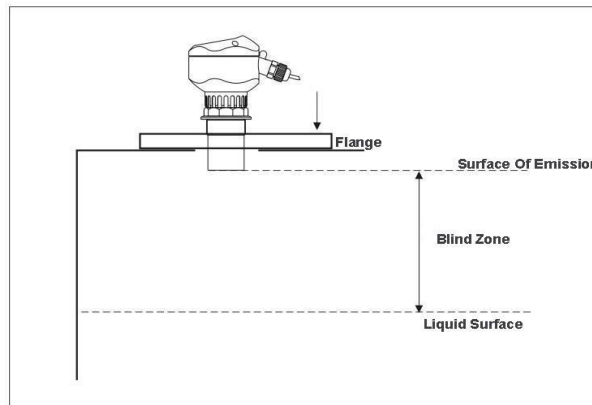

Flange type (locking flange), installed on the flat top tank

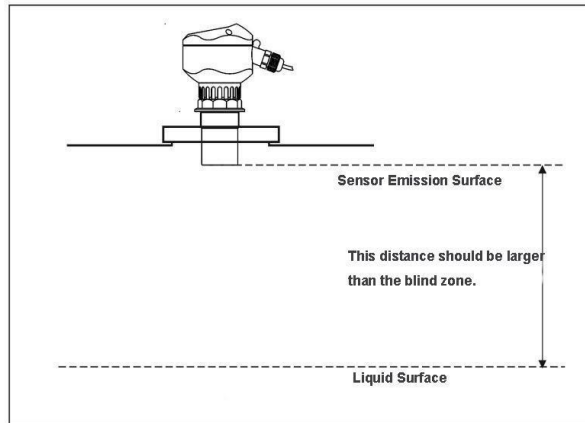

Flange type mounted on non-nozzle flat tank

Mounted on threaded neck same as probe, in such case the diameter of the neck is almost the same as the external thread of the probe, and the emission surface of the probe must be extended over 1cm.

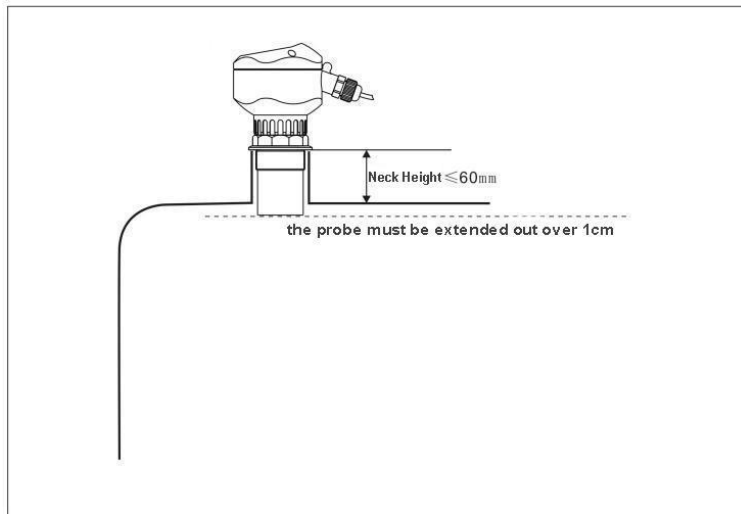

Probe mounted on threaded neck

3.3.2 ARCHED TANK

For arched tank, ultrasonic level meter should be installed in the 1/2 or 2/3 (keep a certain distance from tank wall) of top radius of tank, instead of in the center of tank top. For ultrasonic pulse, arched tank roof is a convex glass, if probe is installed in the focal point, it will receive false echo, so it should be avoided to be installed in the center of the arched tank roof.

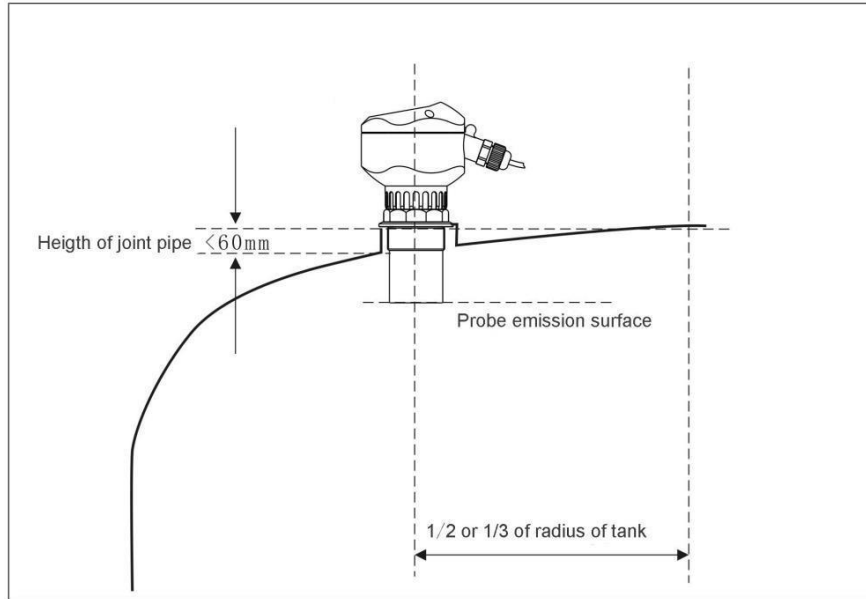

Installed on Nipple Joint—Arched Tank Roof

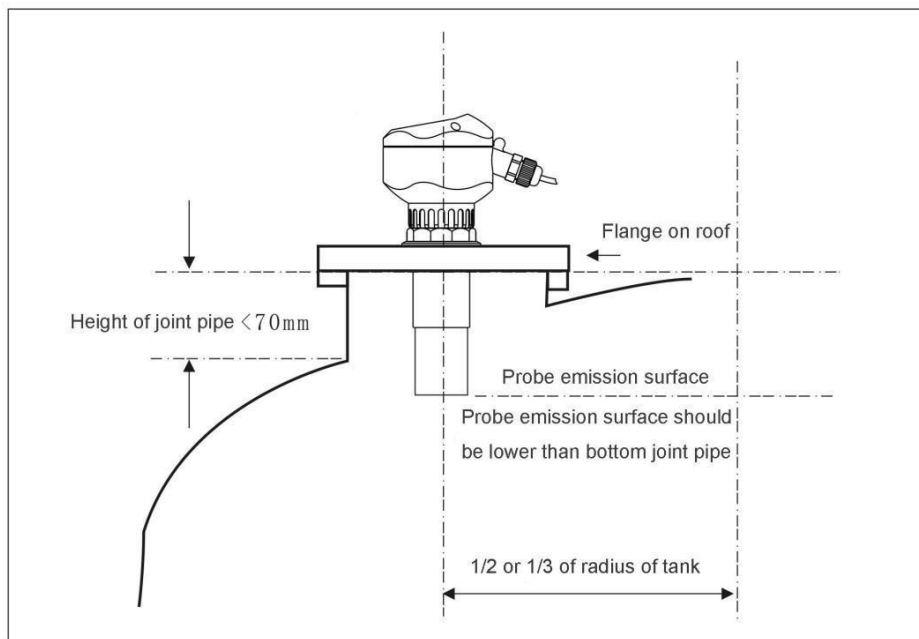

Installed on Flange-- Arched Tank Roof

The length of joint pipe and flange is 150-180mm on many arched tank roof, but the length of probe plus thread is shorter than it (extended probe can be provided to make sure the probe emission surface lower than joint pipe bottom). In this case, we should pay attention to the ratio between length and min diameter size of joint pipe, the downward exit must cut a 45 °angle.



No	Length of joint pipe	Min diameter size of joint pipe	Note
1	150mm	100mm	No burr and protruding object of in wall of joint pipe, keep vertical, all welding joint should be polished, the joint pipe and tank top connection point need make an angle of 45 ° polished from the inside to the outside of the joint pipe.
2	200mm	150mm	
3	250mm	180mm	
4	300mm	220mm	
5	400mm	280mm	

3.3.3 OPEN VESSEL

For open vessel, user can install use bracket, but please pay attention to the weight capacity of bracket and keep a certain distance from probe to the in wall of vessel. If the open vessel or in wall is smooth and no scaffolding, no other objects adhesive to the in wall, the distance from probe to in wall is shown in the following table.

Max measuring range	Min distance from tank wall	Max measuring range	Min distance from tank wall	Max measuring range	Min distance from tank wall
5m	0.5m	10m	1.0m	15m	1.5m
20m	2.5m	30m	3.5m	40m	5m
50m	6m	60m	7m	70m	8m

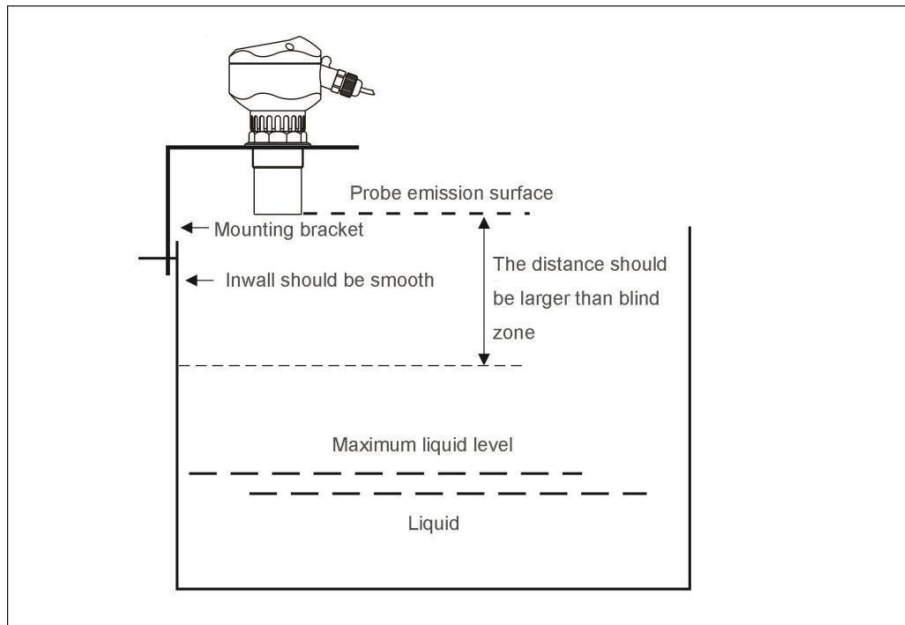

Open Vessel top -side part install one bracket to support



Open vessel don't have focusing effect, probe can be installed in the middle of top.

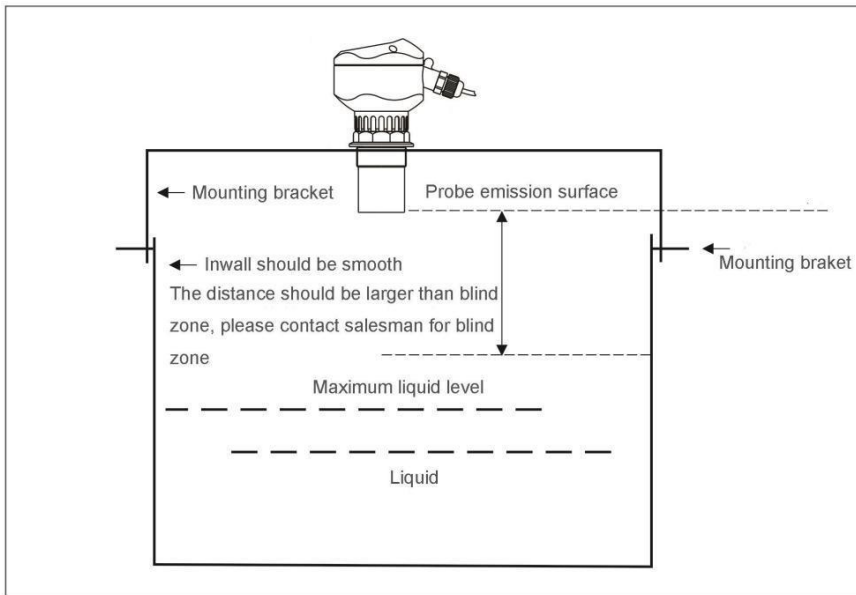

Open Vessel top–installed in the center of the top with bracket

3.3.4 DRAINING WELL AND COMMON WELL

Well hole and wellhead of draining well are narrow, in wall is irregularity and it's difficult to measure. It can be solved by installing guide tube or entire measuring casing, please note that, blind zone will increased to 50~100% if put the sensor into the guide tube, need take it into consideration.

If original blind zone of probe is 0.50m, it will increase to 1.00m after when using guide tube.

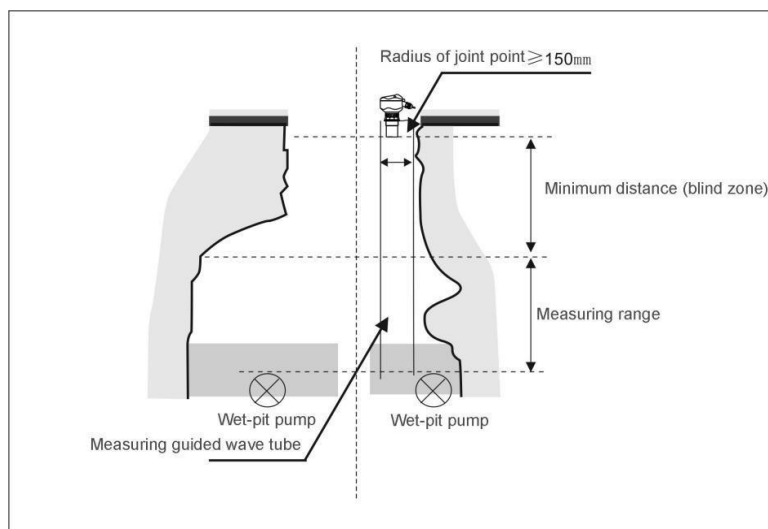

Guide tube and measuring sleeve are used in the measurement of draining well

Generally speaking, Common well (include water supply well and deep well) diameter is not large and can install measuring sleeve to get better measurement. In wall of measuring sleeve



should be smooth (can use PVC and PE), bore size $\geq 150\text{mm}$ (4m measuring range). Please contact us if you need measuring sleeve more than 4m. It can be measured if the measuring sleeve is clean, no adhesive medium and no joint.

Measuring casing should be immersed in the medium which makes sure measurement.

3.3.5 MEASURE SOLID

Flange installation

Same as measuring liquid, ultrasonic level meter can be installed on the counter flange of vessel guide tube, due to the reflecting surface of solid is not a plane as the liquid, so user need take into consideration of this problem. Probe emission surface should be vertical to the solid surface and probe should be extended outward from the guide tube.

In the application of solid measuring, if probe is inside of the guide tube, will result in measuring data fluctuating or sonic wave lose phenomenon under most circumstances.

Universal flange can be used to solve the problem, probe will easily point to solid surface while turning the universal flange.

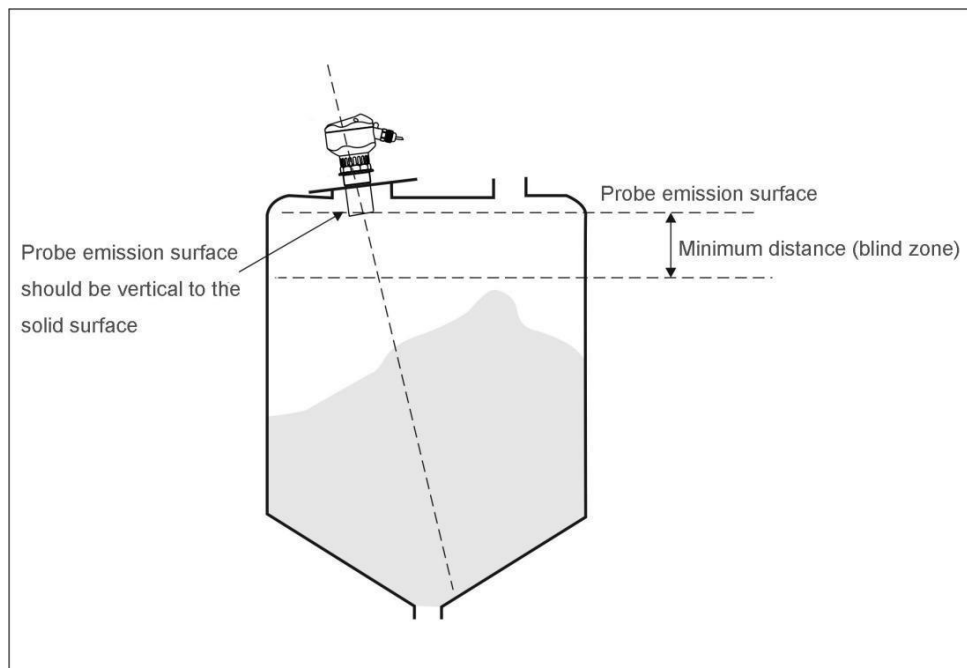

Integral type probe — install on vessel flange

Installation of nipple joint

Probe should be 2cm longer in the bottom side compare with guide tube when install nipple joint.

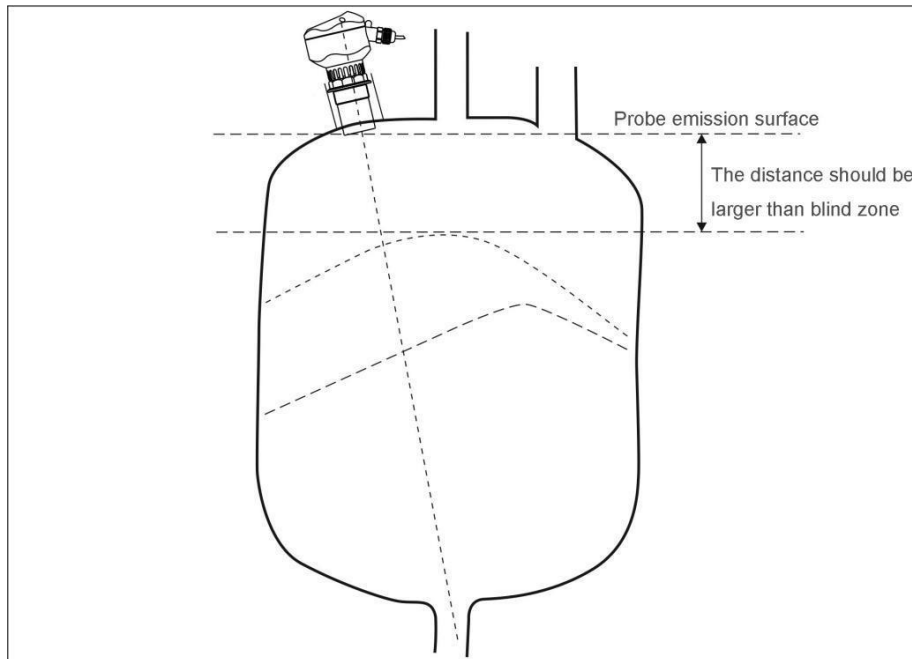

Integral type probe — install on nipple joint

Gantry frame installation

Open vessel can adopt gantry frame installation. Axis of guide tube should point toward with the outlet of vessel or vertical to the medium surface.

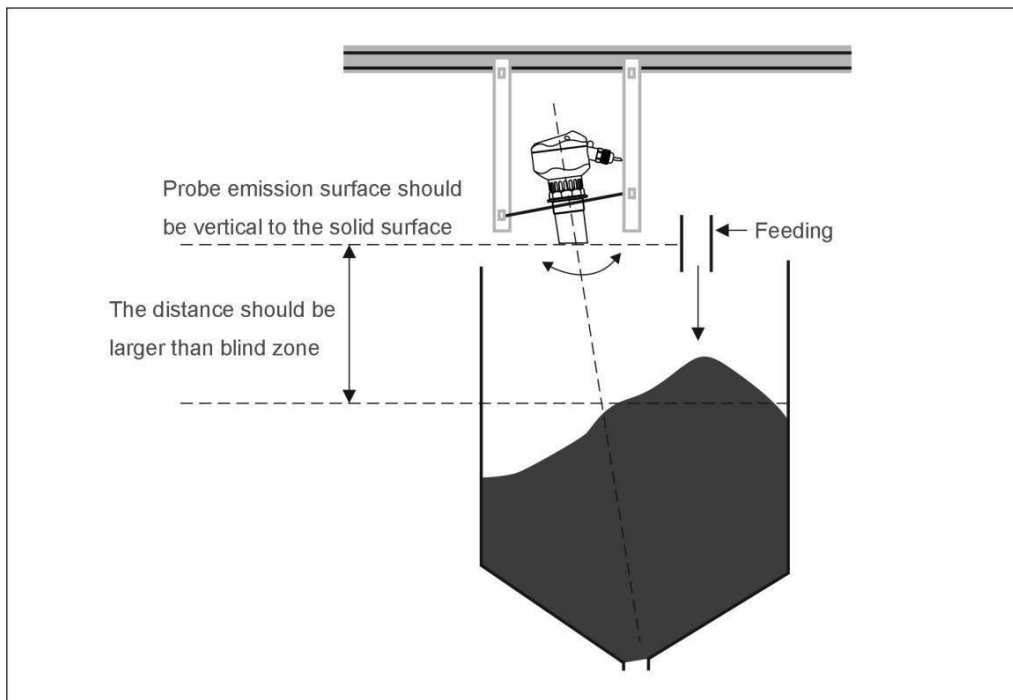

Integral type -- Gantry frame installation



When measure open-pit pile, multiple ultrasonic level meters should be used for large one, they can be installed on hoist frame and probe should point toward the surface of **medium**.

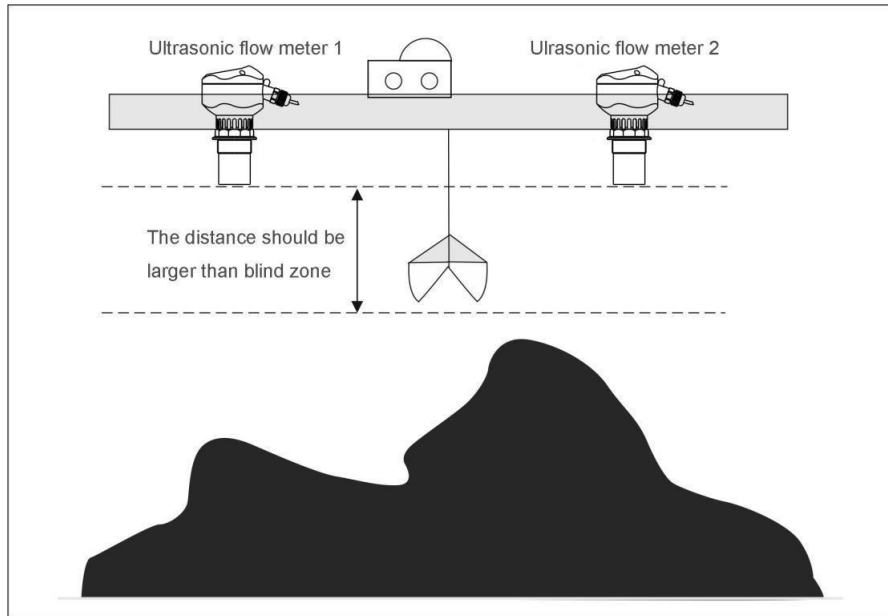

Open-pit pile measurement—installed on hoist frame

3.3.7 3.3.6 HOW TO EXTEND GUIDE TUBE WHEN MEASURE SOLID

Probe should keep the minimum distance from solid surface, this is commonly called blind zone. But site condition can't meet the minimum distance requirements sometimes, one extended guide tube should be installed.

How to extend guide tube when measure liquid

Please try to keep in wall smooth, guide tube should not be immersed in the medium in case of the

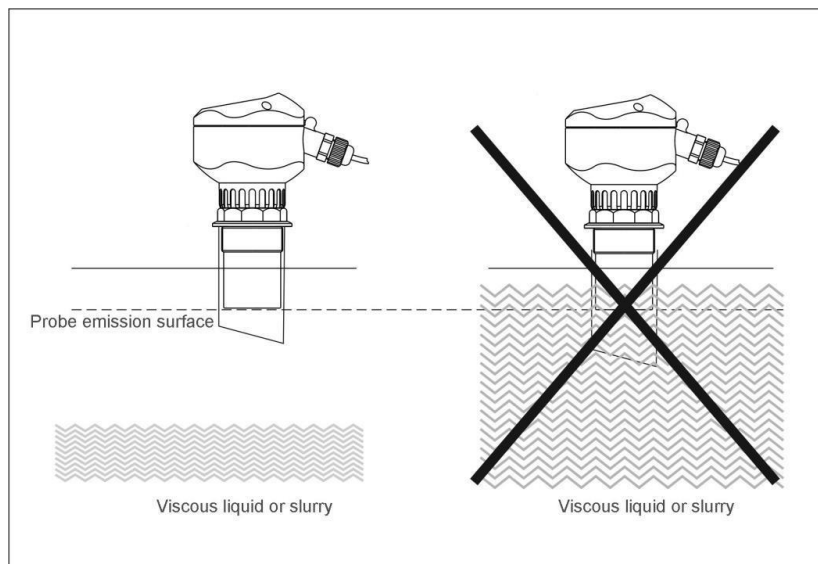



pollution of the medium or adhere to the in wall of guide tube.

Guide tube can't be immersed in adherent medium

If it is non-adhesive medium, the extension guide tube can be immersed in the medium for a long time (can't be corroded by liquid, or without impurities adhere to the inner wall of the pipe), the measurement will be more accurate, because the measurement will not be influenced by others inside of the container. The inner diameter of the guide tube should be as large as possible, and the beveled slit should be smooth. The figure for guide tube length L and min bore size of guide tube is shown in the following table.

No.	Length of guide tube (L)	Min bore size of joint pipe ϕ	Note
1	150mm	100mm	No burr and protruding object of in wall of joint pipe, keep vertical, all welding joint should be polished, the joint pipe and tank top connection point need make an angle of 45 ° polished from the inside to the outside of the joint pipe
2	200mm	150mm	
3	250mm	180mm	
4	300mm	220mm	
5	400mm	280mm	

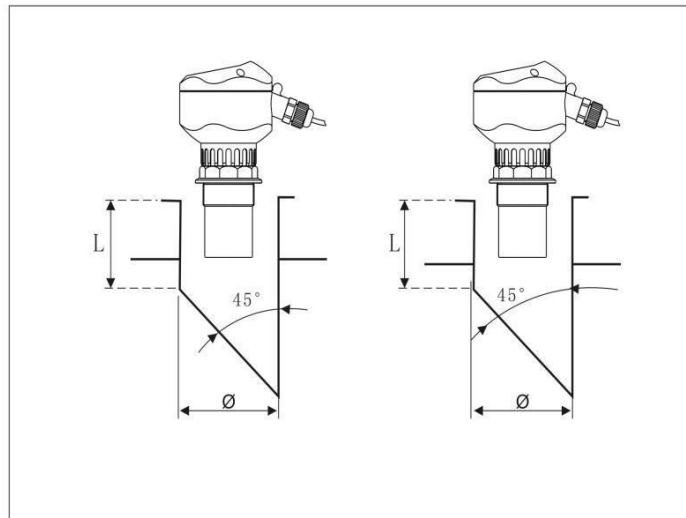

Extended guide tube not immersed in the medium

If extended guide tube is installed from top to bottom of tank, please refer to below figure for measuring range and bore size.

Max measuring range	Min bore size (can be larger)	Max measuring range	Min bore size (can be larger)
5m	150mm	10m	200mm
15m	250mm	20m	300mm

How to expand the measuring solid connection pipe

If the solid medium, unlike the measuring liquid, a tapered extension tube with angle of 25°C~30°C is needed;

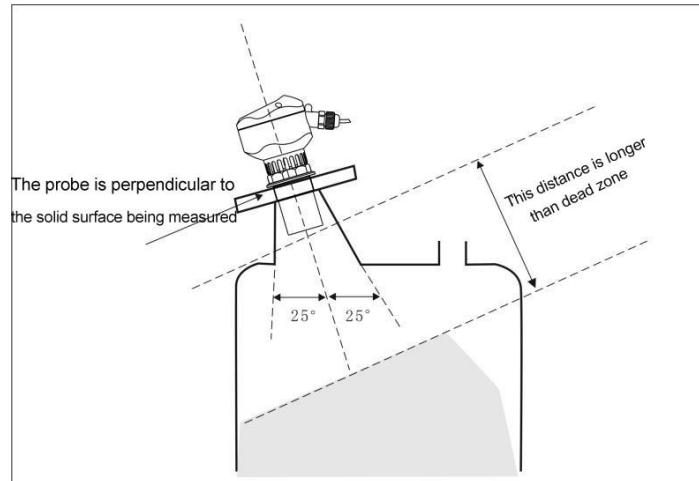

Extension for measuring solid medium

3.3.8 INSTALLATION TO AVOID FALSE ECHOES

The device and installation in the container

When installing the sensor, it must be noted that other device or feeds not allowed to block ultrasonic beam. Bulges or step-like obstacles in the inner surface of the container can greatly influence the measurement, a refractor plate can be put in the bulges to deflect the false echo away, so as to ensure the accuracy of the measurement.

A step-like obstacle in the container--requires an inclined transverse plate to refract the false echo away.

If the upper surface of an object is planar at the bottom of the container, it must be shielded by a refractor plate with a certain angle.

The bottom of the container has a flat-topped protrusion--need to add a refracting plate

The device in the container, such as: tubes and brackets, can affect the measurement. In the design of the measurement point, it must be note that there must be no other devices within the diffusion range of the ultrasonic signal.

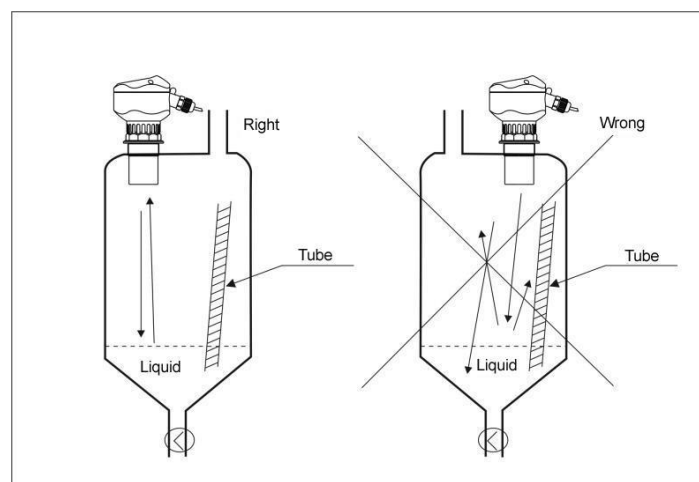

The obstacle inside the container--Tube



Don't install the sensor in or above the feed flow, leaving a certain distance from the feed inlet.

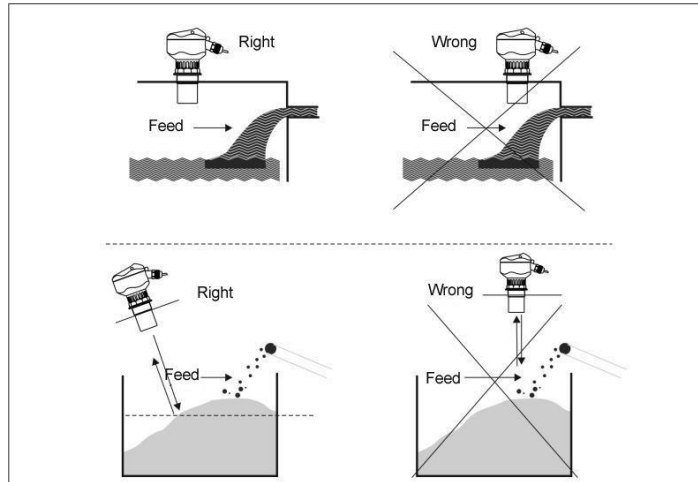

Level meter installation outside the influence of filling

There has adhesive media in the container, such as: crude oil storage tanks, mud tanks, asphalt tanks, cement mixing tanks. If the sensor is installed too closed to the wall of the container, the adhering medium on the wall of the container will cause a strong false echo, so the sensor should be kept at a certain distance from the wall of the container.

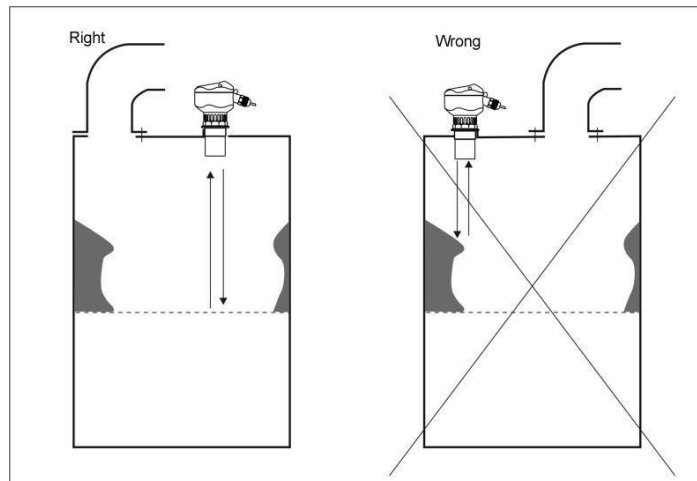

Adherent on the wall of container---keep a distance from the adherent

In the reservoir, usually according to the highest water level to decide the installation height of the instrument, it must be noted that the distance from the highest water level to the sensor, if there is obstacles when low level, it must be refracted with a baffle

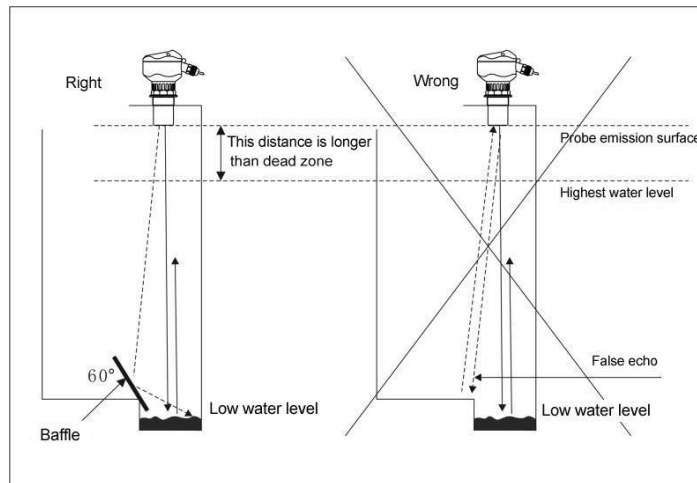

Obstacles at the bottom of the reservoir-- refraction with a baffle

If there are strong eddy, swirl in the container, such as the eddy caused by an agitator or a strong chemical reaction, the measurement will be very difficult. Ideally, the sensor probe can be installed in a wave guide or bypass tube for measurement.

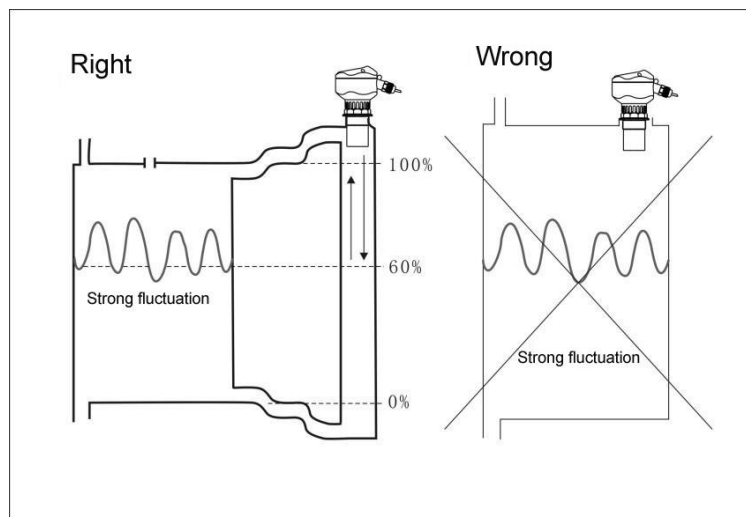

Large fluctuations at the surface of the medium --measured by bypass tube or wave guide tube



Common installation error

Bubble: if the bubble on the surface of the medium is large and the layer of the bubble is thick, the measurement errors occur, the reflected ultrasonic wave may not be received. Take measures to prevent air bubbles from forming, or install the sensor in the bypass tube for measurement.

Bubbles forming working site

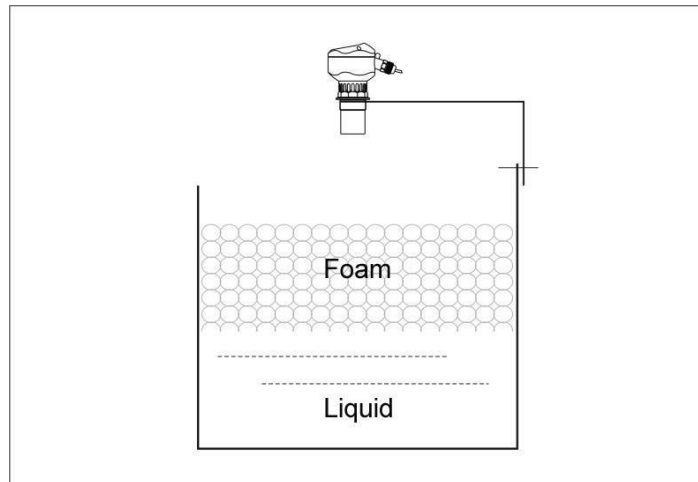

The sensor is installed in the wrong direction

If the sensor is misaligned with the surface of the medium, the measurement signal will be weakened. In order to ensure the best measurement effect, the sensor axis should be aligned to the surface, which is perpendicular to the measured interface surface.

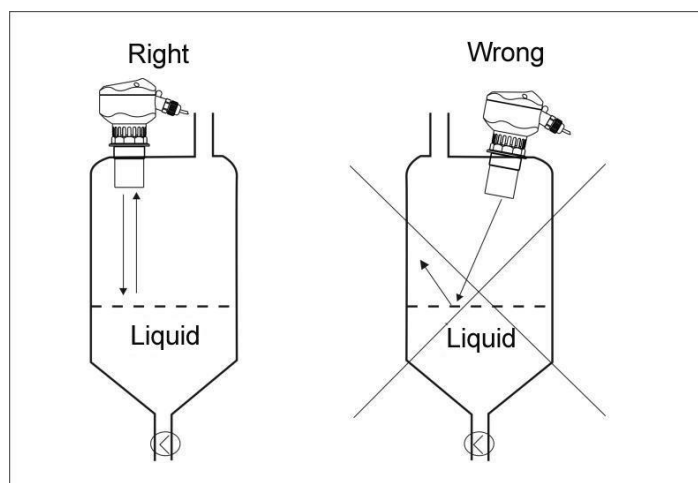

Sensor probe should be perpendicular to the medium surface



Installed in a location with a large temperature variation

In places with large temperature variation, such as strong solar radiation, measurement errors will occur. This error will increase 2-4% based on the original measurement accuracy. Please install a sun visor to solve this problem.

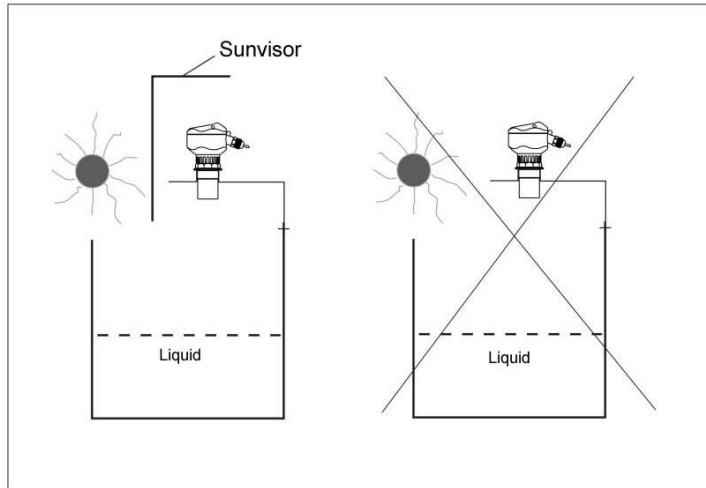

Large temperature change-- Adding sun visor or instrument box

The minimum distance to medium is less than dead zone

If the distance from probe to the highest of the medium is less than dead zone of the level meter, the measured value are all wrong.

The distance of the sensor too close to the container wall

If the distance of the sensor is closed to the wall of container, will produce a strong false echoes. The rugged inner surface of the container wall, the adhered medium, the rivets, screws, ribs and welds on the inner wall of the container create strong false echoes and are loaded on the effective echo signals. Therefore, please note keep the distance between sensor and the container wall according to the maximum distance to be measured. Please see the table blow for details.

Max. range	Distance from the wall	Max. range	Distance from the wall	Max. range	Distance from the wall
5m	0.5m	10m	1.0m	15m	1.5m
20m	2.5m	30m	4m	40m	5m
50m	6 m	60m	7.2m	70m	8.5m

For worse measuring conditions, continue to widen the distance between sensor and the wall of the container until there is no false echoes.



4 ELECTRICAL CONNECTIONS

4.1 SAFETY INSTRUCTIONS



DANGER!

Only when power is switched off, can we do all the work about electrical connections. Please pay all attention to the power supply on the name plate!



DANGER!

Observe the national regulations for electrical installations!



DANGER!

For devices used in hazardous areas, additional safety notes apply; please refer to the Ex documentation.



WARNING!

Observe without fail the local occupational health and safety regulations. Any work done on the electrical components of the measuring device may only be carried out by properly trained specialists.



INFORMATION!

Look at the device nameplate to ensure that the device is delivered according to your order. Check for the correct supply voltage printed on the nameplate.



INFORMATION!

Connect the cable on connector with similar numeral marking

4.2 WIRING

4.2.1 OUTPUT ACTIVE

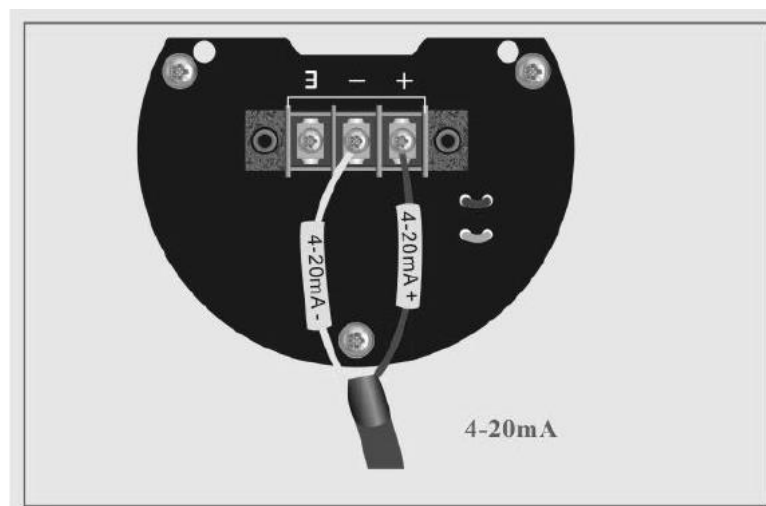



4.2.2 OUTPUT PASSIVE

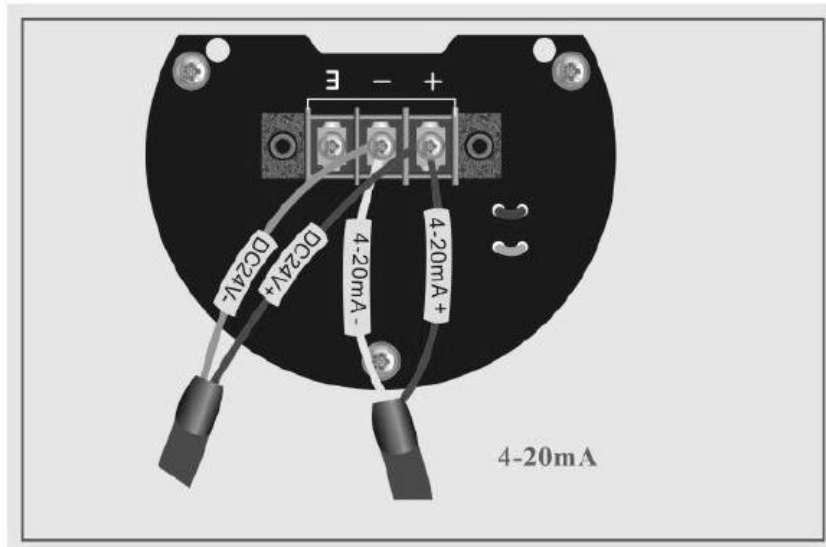



5. OPERATIONS

5.1 INTERFACE IN OPERATION MODE

There are two working modes: operation and setting. It will enter into operation mode automatically and start measuring data after the device is powered on and the initialization process is completed. At this time, the measurement is level measurement mode. And the relative output is 4-20mA. The output current is proportional to the level.



Operation mode interface is as follows:



LCD display screen after opening the cov

❖ BUTTON OPERATION

There are F1, F2 and F3 three buttons



- Press **F3**, enter setting function, can view and modify the parameters;
- Press **F1**, page down (back to previous menu), press F2, page up (turn to the next menu) for three
- Press **F1** Seconds, enter the current menu setting, when the underline goes to the second line, indicating the parameters can be modified;
- Setting data: press F1 modify current data, press F2 right shift setting; Change the options: press F1 page up, press F2 page down;
- Save data: press F1 for three seconds to save the setting; Meanwhile underline return to the first line, then can scroll down the menus by F1 and F2;
- Exit setting: press F3, discard the current setting data; or return to previous menu / exit the setting;



5.2 INTERFACE INTRODUCTION

- LCD adopt 128*64 lattice display, Multi variable simultaneous display is supported.

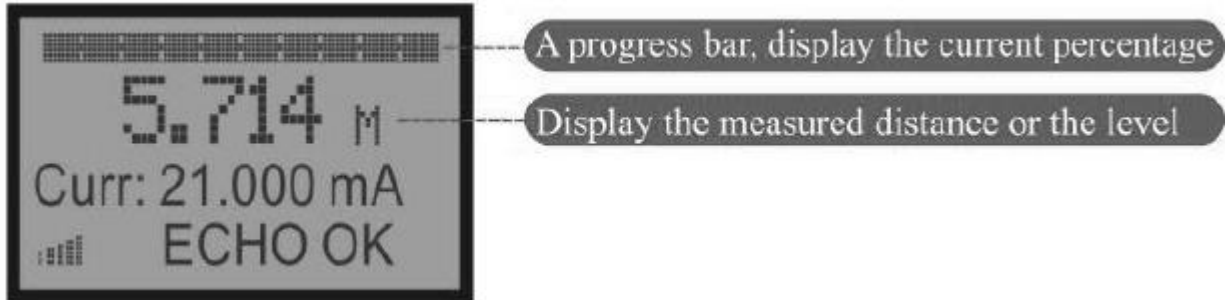

- Press F1 until the second line switch to next data, loosen the button. Then press F1 to show variable switching between percentage, temperature, and distance.

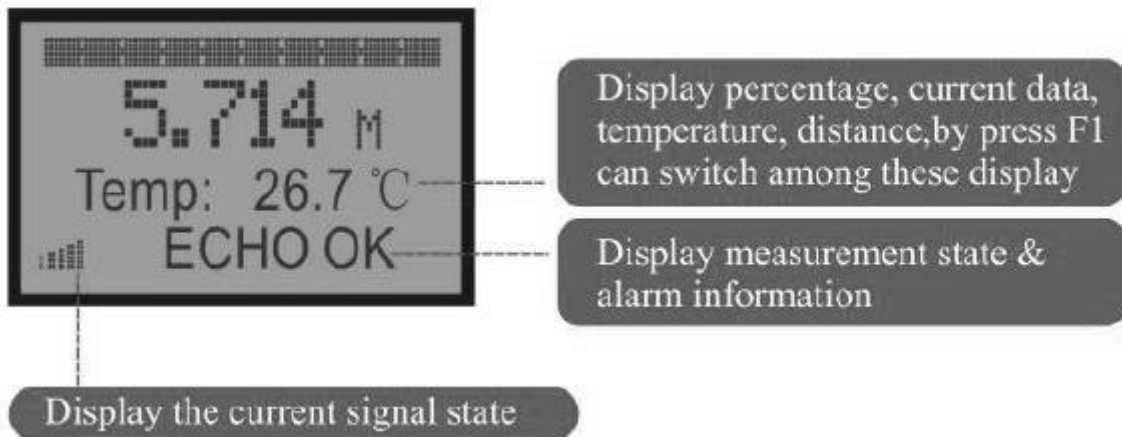

- If there's no signal detected, the signal indicator will disappear.

MEASUREMENT STATUS INTRODUCTION:

ECHO OK	ECHO Measurement is normal, signal strength show on left side
Er:01-Comm fail	Hardware failure
Er:02-Comm Prof	Software version is wrong
Er:03-Echo Loss	ECHO Loss
Er:04-LargeNoise	Excessive signal noise
Alm: Low Limit	Below the low alarm limit
Alm: High Limit	Above the high alarm limit



5.3 OPERATION MENU

5.3.1 BASIC FUNCTION MENU

Contrast	Set the contrast of LCD display.
Protection	Set ON (Write Disable), Parameter are not allowed modified; Set the option "closed (Write Enable), can modify the parameter by pressing button.
Measure Mode	Can set it to measure Distance, level or Empty.
Range Unit	Range unit can be mm, Cm, m, FEET, INCH
Range 100%	Max Range ,Set 20mA output corresponding distance value, level value, or empty value.
Range 0%	Lower Limit Range : Set 4mA output corresponding distance value, or level value, or empty value.
Damping (S)	Set range 0~32 second. Damping time longer, output is more stable, response time is longer
Disp. Point	Set the main variable (data on the first line) the number of digits displayed after the decimal point.
Alarm Low	Set alarm low value, unit is same as the range unit.
Alarm High	Set alarm high, unit is same as the range unit.
Alarm High Hyst.	Set the alarm high hysteresis, unit is same as range unit.
Code	Input password, enter the corresponding advanced function settings.

The password support as follows:

xxxxx : advance setting, include measurement range (Maximum measure length), dead Zone, response rate, Echo algorithm selection and so on;

xxxxx : set false echo suppression, probe excitation frequency; xxxxx : Sound velocity calibration, temperature calibration; xxxxx : check version numb



5.3.2 PASSWORD ***** ENTER CATEGORY OPERATION MENU

Signal Monitor

Can check the current measure distance and signal strength. The farthest signal strength should be more than 1mV.

Slave Address

Set the converter communication address.

Measure Range

Set installation height, this parameter determines max measurement distance, recommended to set according to the actual condition.

Blanking

Set probe dead zone (0.2~2m), suggest to set according to probe parameter.

Response Rate

Set maximum response rate, can choose fast (10m/min), intermediate speed (1.0m/min) or slow (0.1m/min)

Echo Algorithm

Maximum value validation: Select the echo with maximum amplitude as the real echo. First wave: take the first effective echo as the real echo.

In actual use, due to the difference of the measurement environment the user should select the most suitable echo algorithm for measurement.

1.First select the maximum Confirmation algorithm (Factory default setting) for measurement. If it can be measured distance is greater than the actual distance as shown in the fig below, change the algorithm to First Wave & then measure.

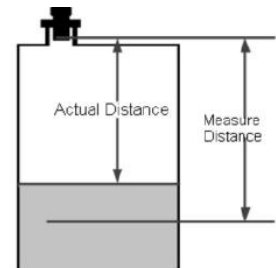

Use the First Wave algorithm for measurement. if the measurement can be done correctly, keep the algorithm unchanged; If the measured distance is smaller than the actual distance as shown in the figure change the algorithm to maximum or First Wave before measuring.

Select the maximum or First Wave only when neither of the first two algorithms can be measured correctly & it will generally work normally after setting. Remember to use the Maximum or First Wave algorithms cannot be measured correctly, otherwise the measurement may be unreliable.

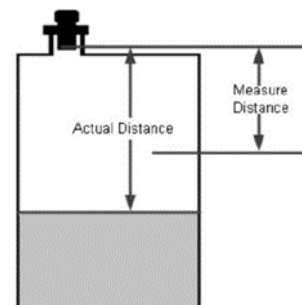



Echo Lock

Off: response to the echo immediately but it is limited by response rate .

Max value mode (Max): when the number of the times for the echo exceeds the set echo sample A or echo sample B, it is the real echo.

Agitator Mode (Agitator): ECHO Sample A default is 5, ECHO Sample B default is 2, work Mode as “max value mode”.

When there is agitator ,make sure choose “max value mode” or “agitator mode”

Sampling A Up

When the number of times for the collected Echo in the upper (closer from the probe) exceed the set value, It is the real echo.

Sampling Down

When the number of times for the collected Echo at the bottom (farther from the probe) exceed the set value, It is the real echo.

Fail Safe Mode

When the equipment failure, there are three modes of the main variable data output: keep the last valid value (Hold), error value, or customized value (Failsafe Value).

Fail Safe Value

User-defined fail-safe value, Unit is same as range unit.

Temp. Unit

Set temperature unit: °C, F, R, K.

Temp. Source

Can choose: sensor, or fixed temperature value.

Fixed Temp



When Temp.source select “fixed temperature”, use this menu to set the temperature value

5.3.3 PASSWORD ***** ENTER CATEGORY OPERATION MENU

Echo Algo.Coef

Set the inhibition strength of false echo, Default is 50%. When there's fake echo which is closer than real echo (closer to the probe) on the field, can increase the inhibition strength.

Noise Level (mV)

When there is “Er:04-LargeNoise”, need to increase the minimum threshold (used to suppress excessive noise in the field). Set range 75~400mV.

Set probe excitation frequency. Current allowed setting range is 30kHz ~50kHz. When need use 15~30KHz excitation, need to be add two capacitors.

5.3.4 PASSWORD ***** ENTER CATEGORY OPERATION MENU

Sensor Freq (Khz)

- ❖ The speed of sound propagation in air and non-air (such as gasoline, acetone, alcohol and many other volatile gases) is different. Therefore, the speed of sound needs to be corrected in non-air situations to eliminate measurement errors caused by sound speed errors.
- ❖ There are 2 ways to correct the speed of sound:
- ❖ First, enter “Calib Sound Speed” Menu,input the actual distance of probe to the liquid level (unit:m),thcn press “F3”is ok.
- ❖ Note: before enter this menu,it displays current sound velocity, enter setting, could input current actual distance for correction.
- ❖ Second: Enter “Sound speed(20°C)” menu, input the sound velocity under 20°C, then press “F3” realize correction.
- ❖ Note: Without correction, use the 343.616m/s(air sound velocity at 20°C)as the default value.

Sound speed (20°C)

Check the sound speed at 20°C after calibration. Can only check, not adjustable.

Set Offset

Can make the measured value bias by set the bias value. If set a positive number, the measured value will be increased.

Temp Offset



When the temperature value is not accurate, can set this value and make the temperature value bias. If set a positive number, the temperature value will be increased.

Temp.Low Trim

Input the current actual temperature value to calibrate the temperature sensor.
Note: Need to be set the menu Temp. High Trim at the same time.

Temp.High Trim



MIAL[®]
INSTRUMENTS PVT.LTD.
Measuring & Beyond

USA OFFICE ADDRESS

MIAL INSTRUMENTS PVT. LTD.
Downtown Republic Center
325 N. St.Paul Street, Suite 3100
Dallas 75201, Texas, USA

FACTORY ADDRESS

MIAL INSTRUMENTS PVT. LTD.
856/ 6 GIDC
Makarpura, Vadodara 390010, Gujarat, India
+91-9913449547/9913449548

Email : info@mialinstruments.com
www.mialinstruments.com



**MIAL
INSTRUMENTS**
Measuring & Beyond

856/6, GIDC MAKARPURA, VADODARA - 390010
Phone : +91-9913449547 Fax : +91-9913449548
E-MAIL : info@mialinstruments.com